

NEW CATALOGUE 2023
LIGHTING FOR THE EARTH

OUTDOOR BOOK

SUSTAINABLE DESIGNS





30
YEARS

Ole! Lighting

www.ole-lighting.com

C/ Germanías, 12-14, Pol. Ind "El Pou"
46960 Aldaia, Valencia, SPAIN

T. +34 961 515 977

F. +34 961 516 290

info@ole-lighting.com

Direct Export

Tel: +34 655 917 238

export@ole-lighting.com

FM Iluminación S.L.U

INDEX BY COLLECTIONS

BIMBA	06
DRUM	10
ILLA	18
KORA	22
MARIOLA	26
ONNA	34
POMA	40
SAVINA	48
TINA	52

COLGANTES / *SUSPENSIONS*

BIMBA 06



DRUM 10



ILLA 18



MARIOLA 26



ONNA 34



POMA 40



SAVINA 48



TINA 52



PLAFONES / CEILINGS

BIMBA 06



DRUM 10



MARIOLA 26



POMA 40



APLIQUES / WALL LAMPS

DRUM 10



KORA 22



LÁMPARAS DE PIE / FLOOR LAMPS

DRUM 10



MARIOLA 26



ONNA 34



MARIOLA 26



POMA 40



OUTDOORS

Artesanal y sostenible. Así es nuestra nueva colección para exterior. Plafones, colgantes, apliques y lámparas de pie con IP66, diseñados con materiales respetuosos con el medioambiente como el esparto y nuestra cuerda trenzada a mano y fabricada con botellas de plástico recicladas.

Handmade & sustainable. This is our new outdoor collection. Ceiling, suspension, wall and floor lamps with IP66, designed with environmentally friendly materials such as esparto grass and hand-braided cord made from recycled plastic bottles.



OCEANS WITHOUT PLASTIC



SUSTAINABLE COMMITMENT



En Ole! Lighting estamos comprometidos con la sostenibilidad, trabajando en el objetivo de lograr un planeta mejor en el que vivir. Con la iniciativa "OCEANS WITHOUT PLASTIC" calculamos que podremos retirar más de 4 toneladas de plástico de nuestro entorno, al fabricar nuestras lámparas de cuerda con botellas de plástico recicladas.

Ole! Lighting is committed to sustainability, working towards the goal of achieving a better planet to live on. With the "OCEANS WITHOUT PLASTIC" initiative we estimate that we will be able to remove more than 4 tons of plastic from our environment by making our textile cord lamps from recycled plastic bottles.



BIMBA

Plafón y colgante preparados para uso exterior. Una pantalla ligera que permite combinar uno o dos colores de cuerda pudiendo así personalizar y adaptar la lámpara al gusto del cliente.

Ceiling and suspension lamp prepared for outdoor use. A gentle lampshade that allows the combination of one or two colours of cord, allowing the lamp to be customized and adapted to the customer's taste.

OCEANS WITHOUT PLASTIC



LÁMPARAS HECHAS DE PLÁSTICO RECICLADO
LAMPS MADE FROM RECYCLED PLASTIC



ODIP30801/80 green



ODIP30811/80 black and silver

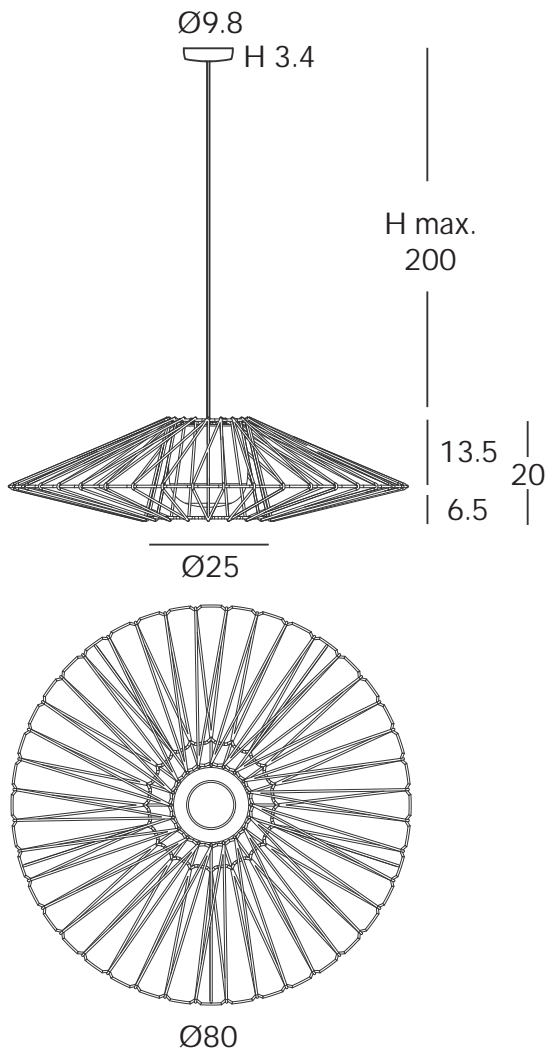

ODIP30801/80

Colgante | *Suspension* IP66

Florón: Negro mate
 Canopy: *Matt black*
 Cable neopreno: Negro
 Neoprene cable: *Black*

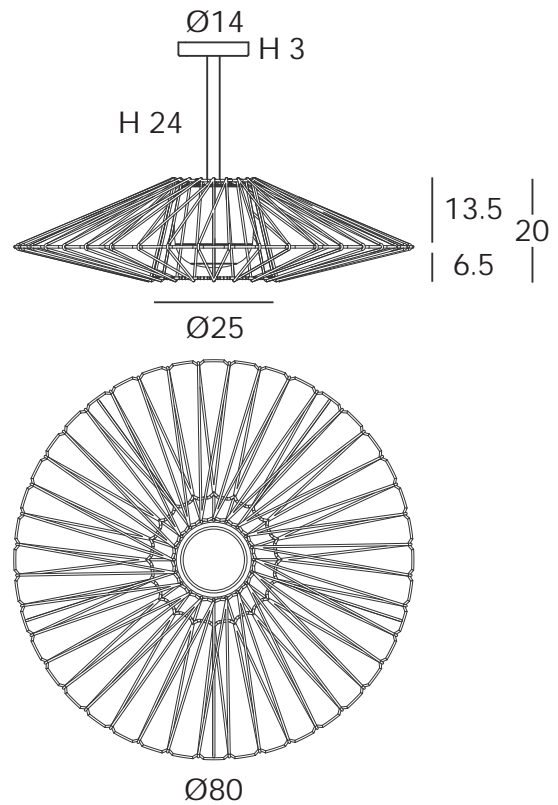

ODIP30811/80

Plafón | *Ceiling* IP66

Tija y base: Negro mate o blanco
 Rod and base: *Matt black or white*

Estructura metálica pantalla: Negra
 Difusor polietileno: Opal mate
 Cuerda: Colores estándar (pag. 56)
 Bombilla: 1 x E27 LED max. 15W Ø6cm

Lampshade metal structure: Black
Polyethylene diffuser: Matt opal
Cord: See standard colors (pag. 56)
Light bulb: 1 x E27 LED max. 15W Ø6cm

(Bombilla NO incluida) / (*Light bulb NOT included*)



DRUM

Esta colección de diseño sencillo se presenta para exterior en forma de plafón, colgante, aplique y lámpara de pie. De esta manera, se podrán crear espacios únicos en los que se conjunte la iluminación y se combinen cualquiera de los 15 colores disponibles.

This simple design collection is available for outdoor use as ceiling, suspension, wall and floor lamps. In this way, you can create unique spaces by matching the lighting and combining any of the 15 available colours.

OCEANS WITHOUT PLASTIC



LÁMPARAS HECHAS DE PLÁSTICO RECICLADO
LAMPS MADE FROM RECYCLED PLASTIC



ODIP24004 lithium



ODIP24900/22 mustard

ODIP24800/s50 mustard



ODIP24000/s50 mustard

ODIP24900/22 mustard



ODIP24900/22 mustard



ODIP24900/22 dark green



ODIP24000/s50 beige



ODIP24800/s50 mustard

ODIP24800/s50

ODIP24000/s50

ODIP24900/22

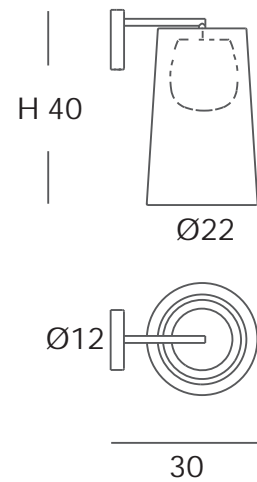
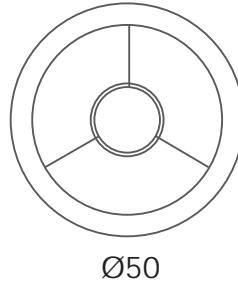
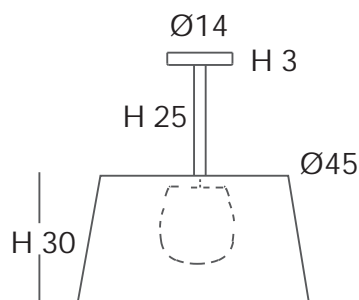
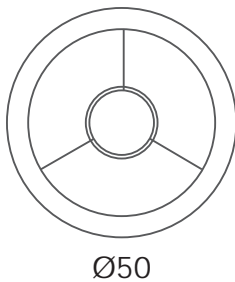
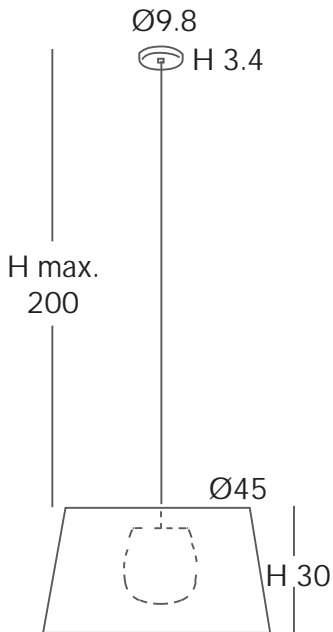

Colgante | Suspension
IP66

Florón: Negro mate o blanco
Canopy: Matt black or white
 Cable neopreno: Negro
Neoprene cable: Black

Plafón y aplique | Ceiling and wall lamp
IP66

Tija: Negro mate o blanco
Rod: Matt black or white

Estructura metálica pantalla: Negra*
 Difusor polietileno: Opal mate
 Cuerda: Colores estándar (pag. 56)
 Bombilla: 1 x E27 LED max. 15W Ø6cm

*Lampshade metal structure: Black**
Polyethylene Diffuser: Matt opal
Cord: See standard colors (pag. 56)
Light bulb: 1 x E27 LED max. 15W Ø6cm

*(Estructura blanca para cuerda blanca) / *(White structure for white cord)

(Bombilla NO incluida) / (Light bulb NOT included)

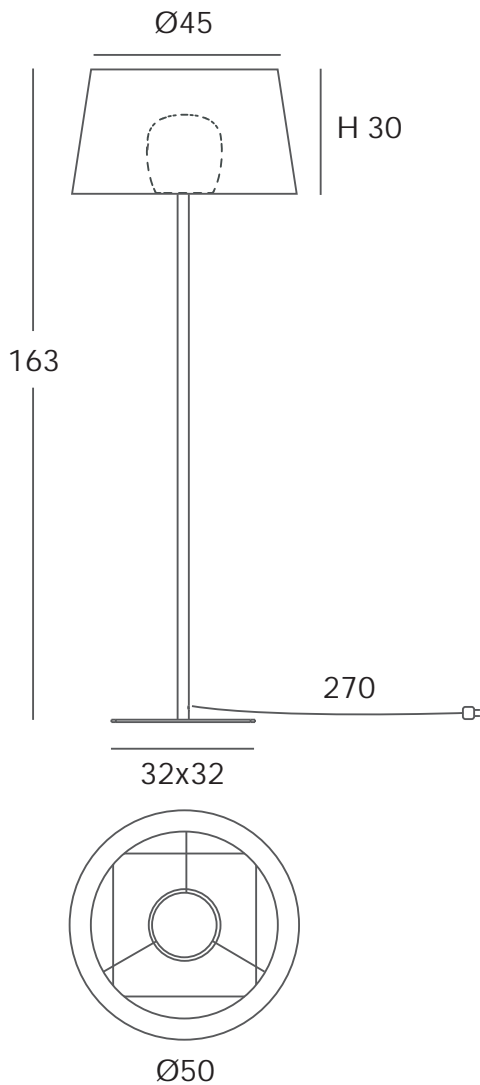
ODIP24004**Pie | Floor lamp IP66**

Pie: Negro texturado o blanco texturado
Clavija y cable (sin interruptor): Negro
Estructura metálica pantalla: Blanca
Difusor polietileno: Opal mate
Cuerda: Colores estándar (pag. 56)
Bombilla: 1 x E27 LED max. 15W $\text{Ø}6\text{cm}$

*Leg. Granulated black or granulated white
Plug and cable (without switch): Black
Lampshade metal structure: White
Polyethylene Diffuser: Matt opal
Cord: See standard colors (pag. 56)
Light bulb: 1 x E27 LED max. 15W $\text{Ø}6\text{cm}$*

(Bombilla NO incluida) / (Light bulb NOT included)



ILLA

Rompiendo con la propuesta de colecciones de cuerda que traemos para exterior, el colgante ILLA se presenta como una opción de iluminación distinta a las demás, donde el esparto se combina con el metal, mezclando lo rústico con lo moderno.

Breaking with the proposal of cord collections that we bring for outdoors, the ILLA pendant is presented as a lighting option different from the others, where esparto grass is combined with metal, mixing the rustic with the modern.



ODIP31820/60



ODIP31820/60

ODIP31820/60
Colgante | Suspension IP66

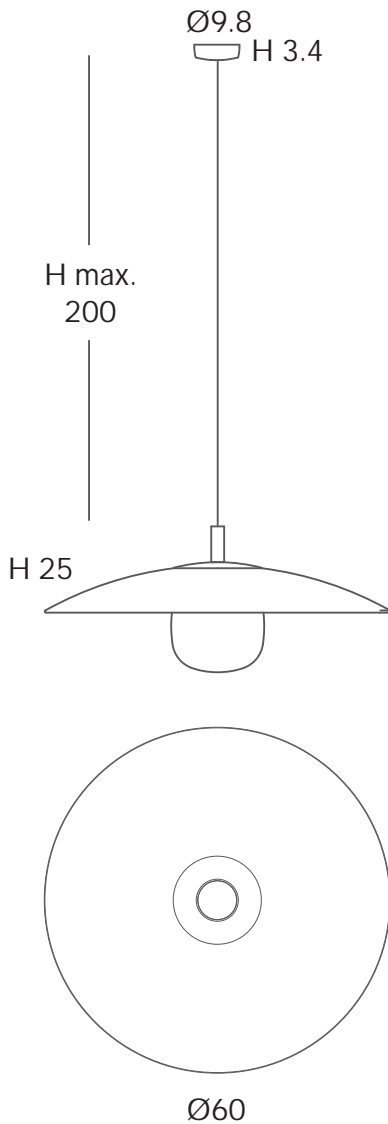

Florón: Negro mate o blanco
 Cable neopreno: Negro
 Cuerpo metálico: Blanco
 Fibra natural: Esparto
 Difusor polietileno: Opal mate
 Bombilla: 1 x E27 LED max. 15W Ø6cm

Canopy: Matt black or white
Neoprene cable: Black
Metal body: White
Natural fiber: Esparto grass
Polyethylene Diffuser: Matt opal
Light bulb: 1 x E27 LED max. 15W Ø6cm

(Bombilla NO incluida) / (Light bulb NOT included)



KORA

De la colección KORA nace este aplique para combinar con cualquiera de las demás colecciones de cuerda. Un modelo elegante y sostenible que encaja en cualquier diseño exterior.

From KORA collection comes this wall light to combine with any of the other cord collections. An elegant and sustainable model that fits in any exterior design.

OCEANS WITHOUT PLASTIC



LÁMPARAS HECHAS DE PLÁSTICO RECICLADO
LAMPS MADE FROM RECYCLED PLASTIC



ODIP26900/28 black



ODIP26900/28 black

ODIP26900/28
Applique | Wall lamp IP66

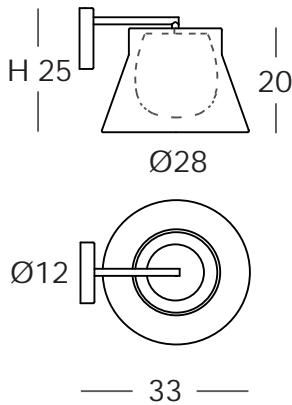

Tija y base: Negro mate o blanco
Estructura metálica pantalla: Negra*
Difusor polietileno: Opal mate
Cuerda: Colores estándar (pag. 56)
Bombilla: 1 x E27 LED max. 15W Ø6cm

*Rod and base: Matt black or white
Lampshade metal structure: Black*
Polyethylene diffuser: Matt opal
Cord: See standard colors (pag. 56)
Light bulb: 1 x E27 LED max. 15W Ø6cm*

*(Estructura blanca para cuerda blanca) / *(White structure for white cord)

(Bombilla NO incluida) / (Light bulb NOT included)



MARIOLA

Con su estructura metálica visible y la trama caleidoscópica de cuerda sostenible, MARIOLA genera una dispersión de luz única creando una agradable atmosfera.

With its visible metal structure and the kaleidoscopic weave of sustainable cord, MARIOLA generates a unique light dispersion creating a pleasant atmosphere.

OCEANS WITHOUT PLASTIC



LÁMPARAS HECHAS DE PLÁSTICO RECICLADO
LAMPS MADE FROM RECYCLED PLASTIC



ODIP31000/50 brown



©DIP31800/s50 beige



ODIP31800/80 stone



ODIP31004 lithium



ODIP31008 mustard

ODIP31000/50

ODIP31800/s50

ODIP31800/80

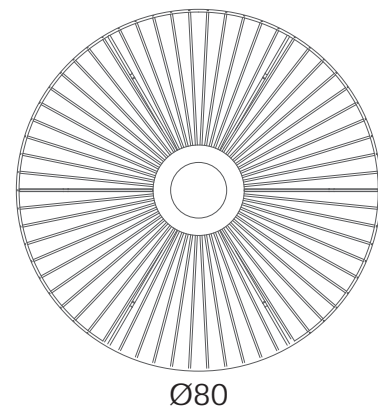
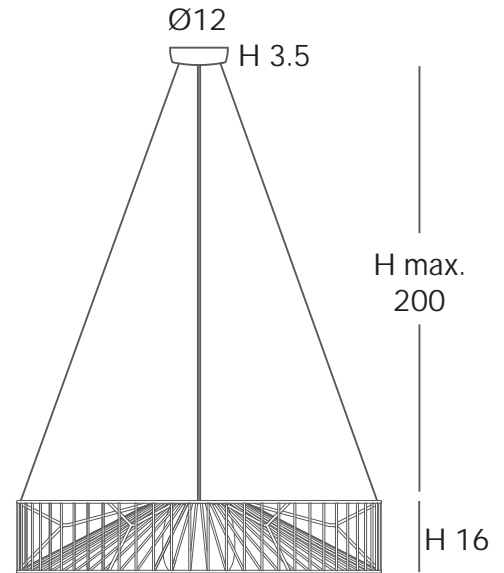
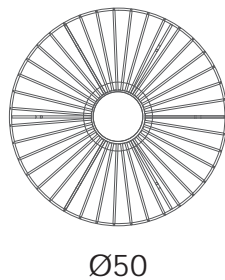
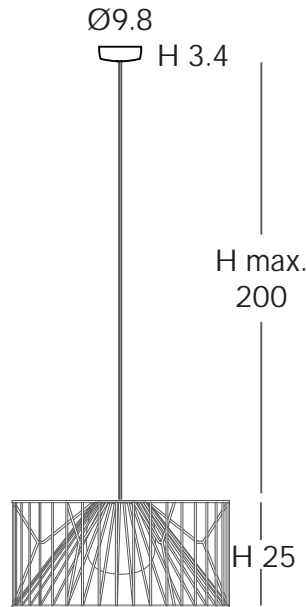
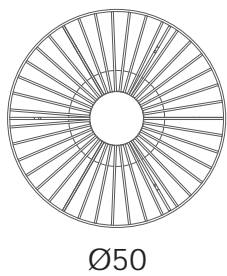
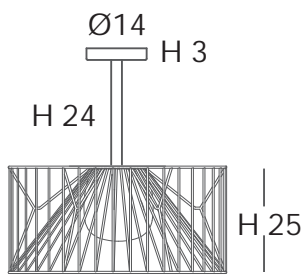

Plafón | Ceiling IP66

Tija y base: Negro mate o blanco
 Rod and base: Matt black or white

Colgantes | Suspensions IP66

Florón: Negro mate o blanco
 Canopy: Matt black or white
 Cable neopreno: Negro
 Neoprene cable: Black

Estructura metálica pantalla: Blanca o arena
 Difusor polietileno: Opal mate
 Cuerda: Colores estándar (pag. 56)
 Bombilla: 1 x E27 LED max. 15W Ø6cm

Lampshade metal structure: White or sand
 Polyethylene diffuser: Matt opal
 Cord: See standard colors (pag. 56)
 Light bulb: 1 x E27 LED max. 15W Ø6cm

(Bombilla NO incluida) / (Light bulb NOT included)

ODIP31004

Pie | Floor lamp IP66

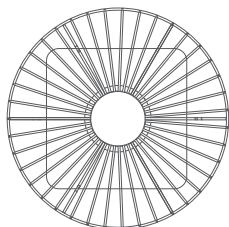
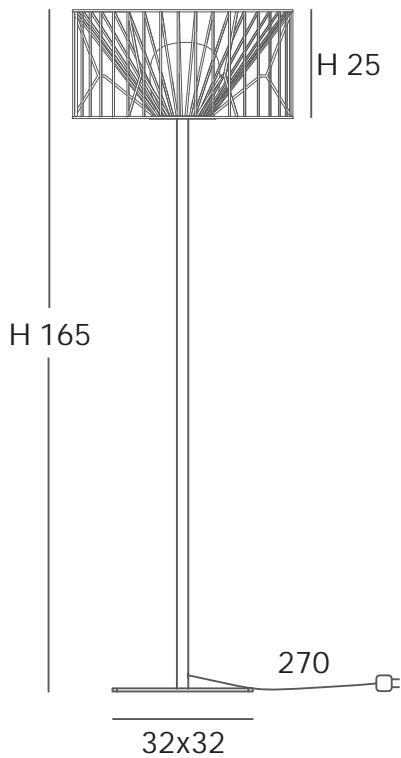

Ø50

ODIP31008

Pie | Floor lamp IP66

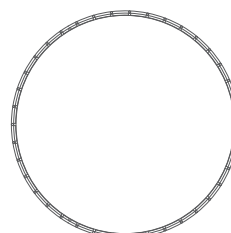
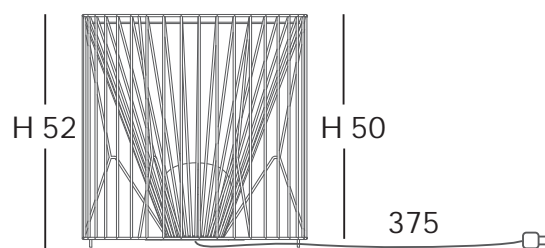

Ø50

Peso máx. soporte 5 kg
Max. support weight 5 kg

Estructura metálica pantalla: Blanca o arena
Difusor polietileno: Opal mate
Cuerda: Colores estándar (pag. 56)
Pie: Negro texturado o blanco texturado
Clavija y cable (sin interruptor): Negro
Bombilla: 1 x E27 LED max. 15W Ø6cm

Lampshade metal structure: White or sand
Polyethylene Diffuser: Matt opal
Cord: See standard colors (pag. 56)
Leg: Granulated black or granulated white
Plug and cable (without switch): Black
Light bulb: 1 x E27 LED max. 15W Ø6cm

(Bombilla NO incluida) / (Light bulb NOT included)



ONNA

Hemos adaptado para exterior este diseño de Nacho Timón, donde las cuerdas se entrelazan entre si creando un caos organizado, que se extiende por la estructura metálica generando volúmenes en cada una de sus caras.

We have adapted for outdoor use this collection designed by Nacho Timón, where the cords intertwine with each other creating an organised chaos, which extends across the metal structure generating volumes on each of its faces.

OCEANS WITHOUT PLASTIC



LÁMPARAS HECHAS DE PLÁSTICO RECICLADO
LAMPS MADE FROM RECYCLED PLASTIC



ODIP31890/52 stone



ODIP31890/42 mustard



ODIP31890/52 stone



ODIP31092 silver



ODIP31092 silver

ODIP31890/42

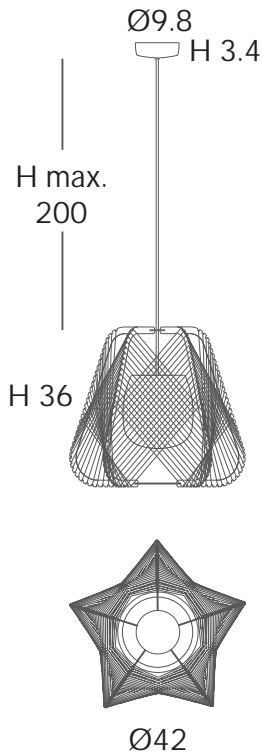

ODIP31890/52

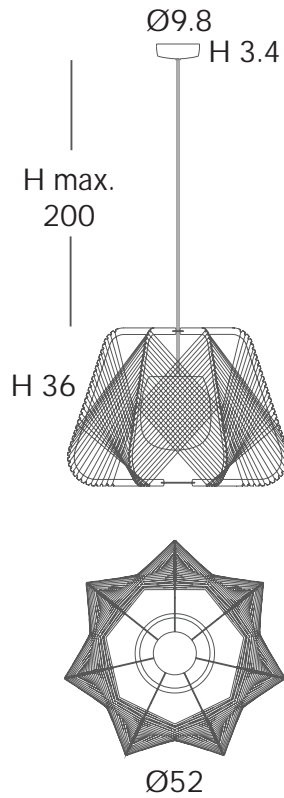

ODIP31092

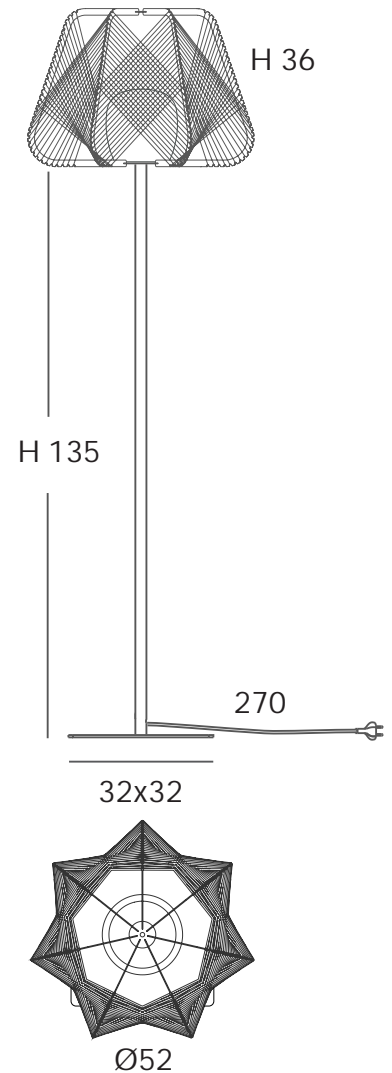

Colgantes | Suspensions IP66

Florón: Negro mate o blanco
 Canopy: Matt black or white
 Cable neopreno: Negro
 Neoprene cable: Black

Pie | Floor lamp IP66

Pie: Negro texturado o blanco texturado
 Leg: Granulated black or granulated white
 Clavija y cable (sin interruptor): Negro
 Plug and cable (without switch): Black

Estructura metálica pantalla: Negra o blanca
 Difusor polietileno: Opal mate
 Cuerda: Colores estándar (pag. 56)
 Bombilla: 1 x E27 LED max. 15W Ø6cm

Lampshade metal structure: Black or white
 Polyethylene Diffuser: Matt opal
 Cord: See standard colors (pag. 56)
 Light bulb: 1 x E27 LED max. 15W Ø6cm

(Bombilla NO incluida) / (Light bulb NOT included)



POMA

Readaptada para exterior, la colección POMA filtra la luz de forma original a través de las cuerdas trenzadas en zig-zag. Colgantes, plafones y nuevas lámparas de pie con IP66 componen esta familia.

Readapted for outdoor use, the POMA collection filters the light in an original way through the zig-zag braided cords. Suspensions, ceiling lights and new floor lamps make up this family.

OCEANS WITHOUT PLASTIC



LÁMPARAS HECHAS DE PLÁSTICO RECICLADO
LAMPS MADE FROM RECYCLED PLASTIC



ODIP29830/75 mustard ODIP29830/60 dark green ODIP29830/45 green



ODIP29831/75 blue

ODIP29831/60 white



ODIP29831/75 blue



ODIP29034/45 silver

ODIP29034/75 stone



ODIP29034/45 silver



ODIP29034/75 stone

ODIP29830/45
Colgante | *Suspension*
IP66

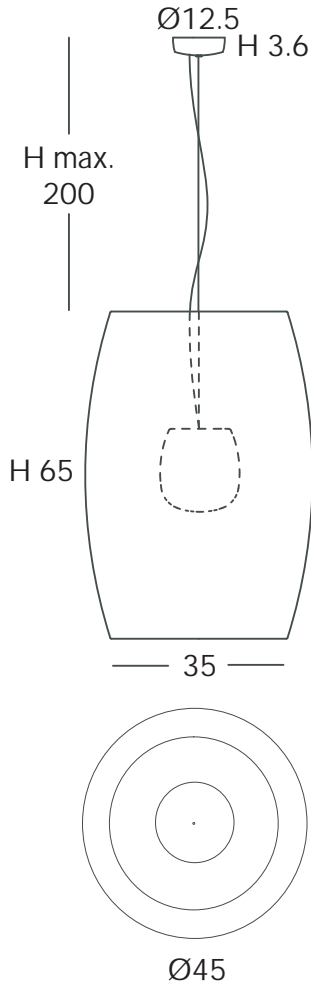

ODIP29830/60
Colgante | *Suspension*
IP66

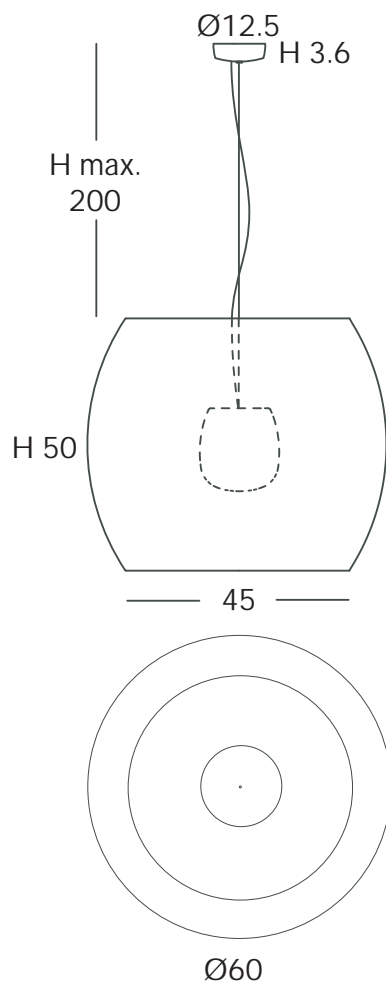

ODIP29830/75
Colgante | *Suspension*
IP66

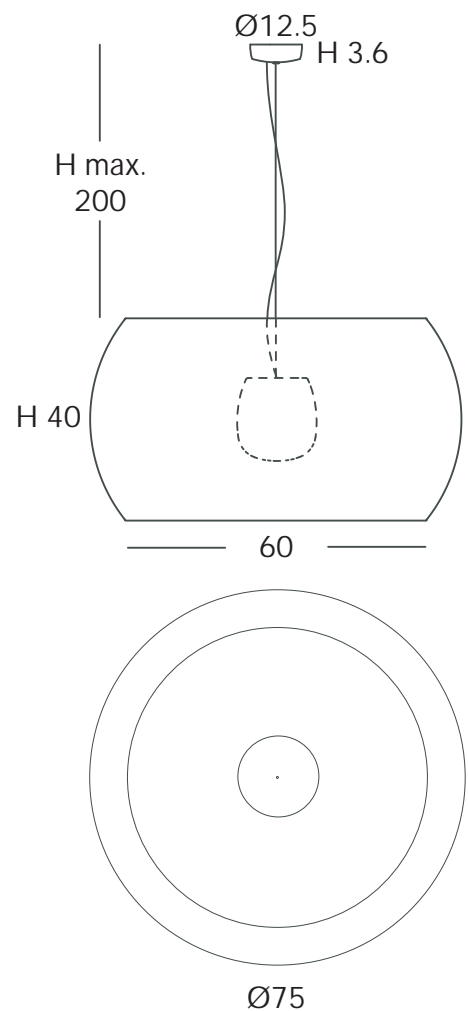

Florón: Negro mate o blanco
Cable neopreno: Negro
Estructura metálica pantalla: Negra o blanca*
Difusor polietileno: Opal mate
Cuerda: Colores estándar (pag. 56)
Bombilla: 1 x E27 LED max. 15W Ø6cm

Canopy: Matt black or white
Neoprene cable: Black
*Lampshade metal structure: Black or white**
Polyethylene diffuser: Matt opal
Cord: See standard colors (pag. 56)
Light bulb: 1 x E27 LED max. 15W Ø6cm

*Estructura negra para cuerda: negro, gris, plata, litio, alga, rojo, granate, indigo y tabaco.
Estructura blanca para cuerda: blanco, mazapán, beige, mostaza, verde y marsala.

**Black structure for cords: black, grey, silver, lithium, dark green, red, maroon, blue and brown.*
White structure for cords: white, stone, beige, mustard, green and marsala.

(Bombilla NO incluida) / (Light bulb NOT included)

ODIP29831/60
Plafón | Ceiling IP66

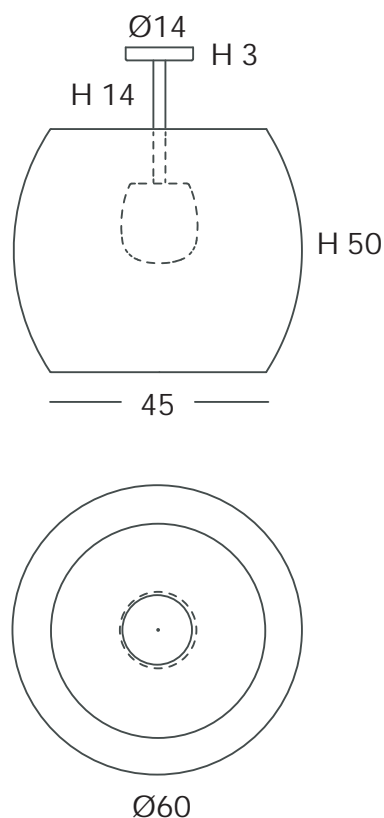

ODIP29831/75
Plafón | Ceiling IP66

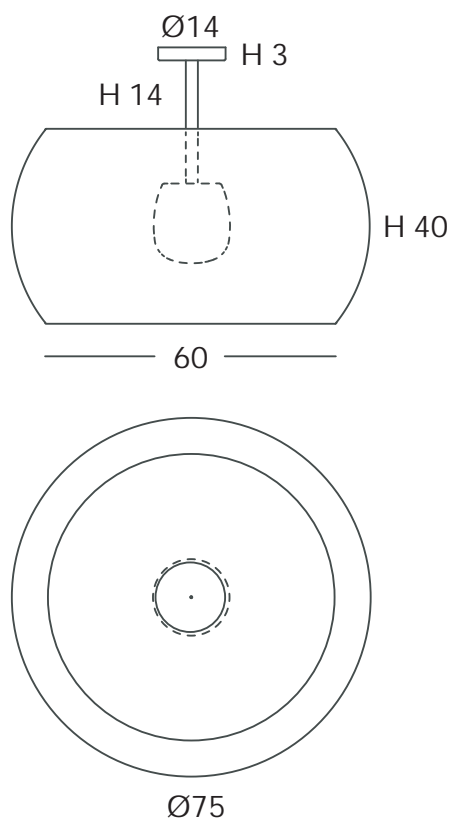

Tija y base: Negro mate o blanco
Estructura metálica pantalla: Negra o blanca*
Difusor polietileno: Opal mate
Cuerda: Colores estándar (pag. 56)
Bombilla: 1 x E27 LED max. 15W Ø6cm

Rod and base: Matt black or white
Lampshade metal structure: Black or white*
Polyethylene diffuser: Matt opal
Cord: See standard colors (pag. 56)
Light bulb: 1 x E27 LED max. 15W Ø6cm

*Estructura negra para cuerda: negro, gris, plata, litio, alga, rojo, granate, indigo y tabaco.
Estructura blanca para cuerda: blanco, mazapán, beige, mostaza, verde y marsala.

*Black structure for cords: black, grey, silver, lithium, dark green, red, maroon, blue and brown.
White structure for cords: white, stone, beige, mustard, green and marsala.

(Bombilla NO incluida) / (Light bulb NOT included)

ODIP29034/45
Pie | Floor lamp IP66

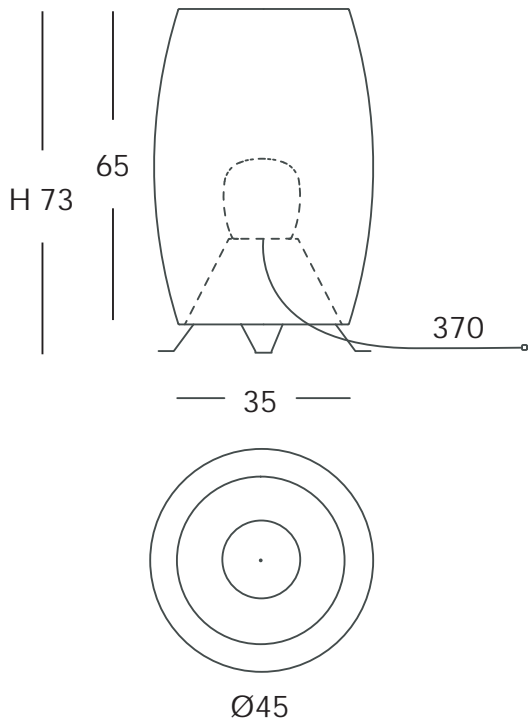

ODIP29034/75
Pie | Floor lamp IP66

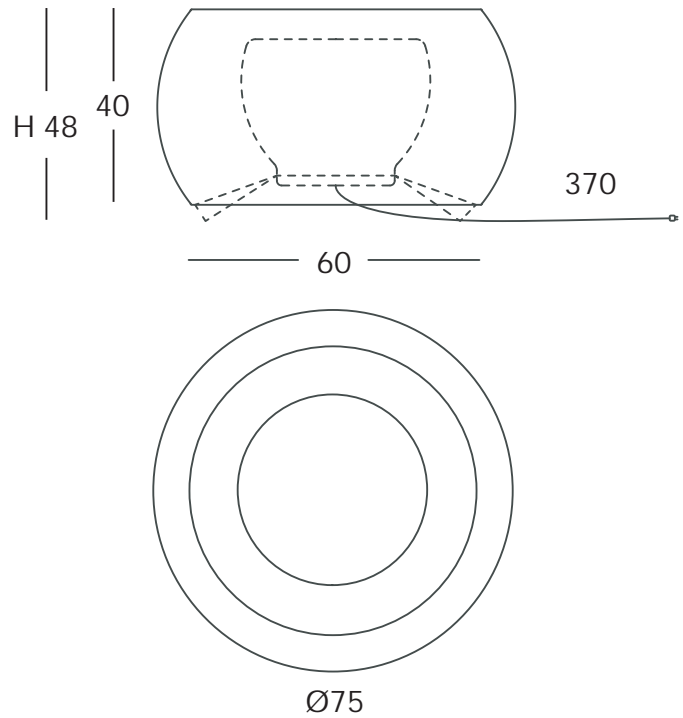

Estructura metálica pantalla: Negra o blanca*
 Difusor polietileno: Opal mate
 Cuerda: Colores estándar (pag. 56)
 Pie: Negro texturado o blanco texturado
 Clavija y cable (sin interruptor): Negro
 Bombilla: 1 x E27 LED max. 15W Ø6cm

Lampshade metal structure: Black or white*
 Polyethylene diffuser: Matt opal
 Cord: See standard colors (pag. 56)
 Leg: Granulated black or granulated white
 Plug and cable (without switch): Black
 Light bulb: 1 x E27 LED max. 15W Ø6cm

*Estructura negra para cuerda: negro, gris, plata, litio, alga, rojo, granate, indigo y tabaco.
 Estructura blanca para cuerda: blanco, mazapán, beige, mostaza, verde y marsala.

*Black structure for cords: black, grey, silver, lithium, dark green, red, maroon, blue and brown.
 White structure for cords: white, stone, beige, mustard, green and marsala.

(Bombilla NO incluida) / (Light bulb NOT included)



SAVINA

Estos colgantes se caracterizan por su diseño de forma cónica que les aporta una figura elegante y estilizada. Combina sus dos tamaños y juega con las alturas para crear espacios con una estética sorprendente.

Suspension lamps of conical design that gives them an elegant and stylised figure. Combine its two sizes and play with heights to create spaces with an amazing aesthetic.

OCEANS WITHOUT PLASTIC



LÁMPARAS HECHAS DE PLÁSTICO RECICLADO
LAMPS MADE FROM RECYCLED PLASTIC



ODIP29811/25 blue



ODIP29811/25 white



ODIP29811/25 mustard

ODIP29811/25
Colgante | *Suspension* IP66

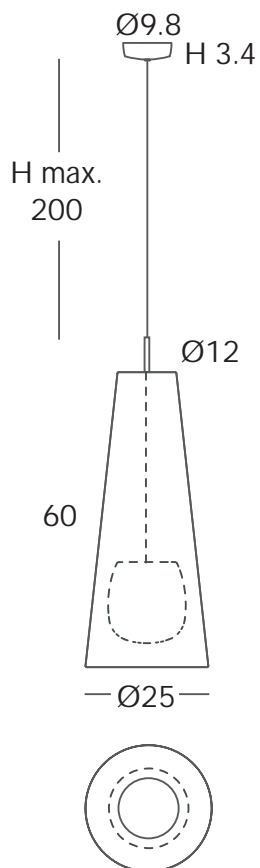

ODIP29811/35
Colgante | *Suspension* IP66

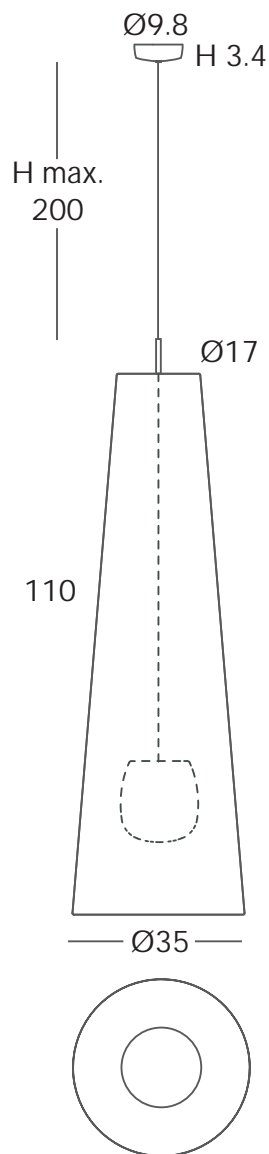

Florón: Negro mate o blanco
Cable neopreno: Negro
Estructura metálica pantalla: Negra*
Difusor polietileno: Opal mate
Cuerda: Colores estándar (pag. 56)
Bombilla: 1 x E27 LED max. 15W Ø6cm

Canopy: Matt black or white
Neoprene cable: Black
*Lampshade metal structure: Black**
Polyethylene diffuser: Matt opal
Cord: See standard colors (pag. 56)
Light bulb: 1 x E27 LED max. 15W Ø6cm

*(Estructura blanca para cuerda blanca) / *(White structure for white cord)

(Bombilla NO incluida) / (Light bulb NOT included)



TINA

Inspirado en cántaros de arcilla, en este colgante la luz se tamiza a través de las dos capas de cuerda creando ambientes cálidos y acogedores.

In this suspension inspired by clay pitchers, light is filtered through two layers of cord creating a warm and cozy ambience.

OCEANS WITHOUT PLASTIC



LÁMPARAS HECHAS DE PLÁSTICO RECICLADO
LAMPS MADE FROM RECYCLED PLASTIC



ODIP29840/50 white



ODIP29840/50 stone

ODIP29840/50

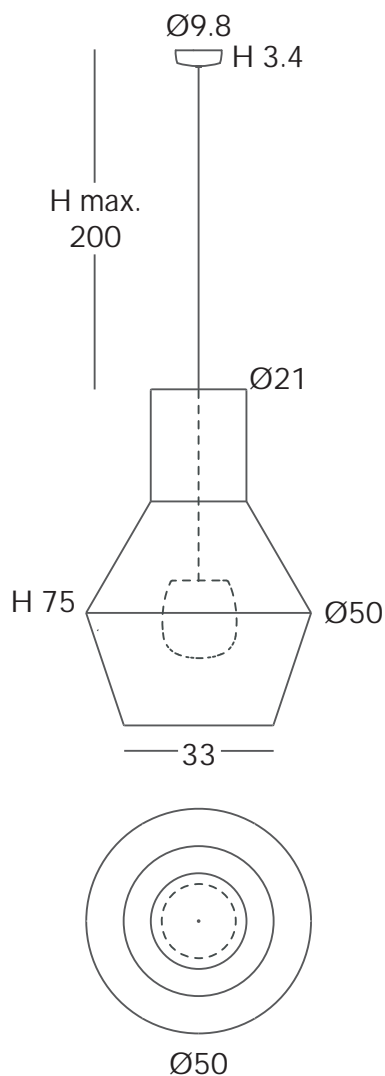
Colgante | *Suspension* IP66

Florón: Negro mate o blanco
 Cable neopreno: Negro
 Estructura metálica pantalla: Negra*
 Difusor polietileno: Opal mate
 Cuerda: Colores estándar (pag. 56)
 Bombilla: 1 x E27 LED max. 15W Ø6cm

Canopy: Matt black or white
Neoprene cable: Black
*Lampshade metal structure: Black**
Polyethylene diffuser: Matt opal
Cord: See standard colors (pag. 56)
Light bulb: 1 x E27 LED max. 15W Ø6cm

* (Estructura blanca para cuerda blanca) / *(White structure for white cord)

(Bombilla NO incluida) / (Light bulb NOT included)

OCEANS WITHOUT PLASTIC



COLORES ESTÁNDAR / STANDARD COLOURS

Cuerda fabricada con botellas de plástico recicladas
Cord made from recycled plastic bottles



1196
Mazapán / Stone
Pant. 7528C



196
Beige
Pant. 727C



168
Mostaza / Moustard
Pant. 1245C



61
Indigo / Blue
Pant. 653C



273
Marsala
Pant. 695C



245
Rojo / Red
Pant. 185C



71
Blanco / White
Pant. White



129
Plata / Silver
Pant. Cool gray 7C



2621
Litio / Lithium
Pant. 5425C



2214
Verde / Green
Pant. 374C



301
Alga / Dark green
Pant. 5615C



120
Gris / Grey
Pant. Cool Gray 10C



224
Granate / Maroon
Pant. 1955C



203
Tabaco / Brown
Pant. 1545C



211
Negro / Black
Pant. Black C

El color Pantone es orientativo / *Pantone color is illustrative*

NUESTRAS ETIQUETAS ECO OUR ECO LABELS

Encuentra nuestras exclusivas etiquetas de papel ecológico en todos los diseños de cuerda. Con ellas, tú y tus clientes conoceréis el número equivalente de botellas de plástico de 1,5 litros que nos ayudas a retirar del medio ambiente con cada modelo de cuerda. ¡Cuanta más cuerda, más botellas!

Find our exclusive eco paper labels on all the cord designs! With them you and your clients will know the equivalent number of 1,5 liters plastic bottles that you help us to remove from the environment with each cord model. The more cord, the more bottles! Every plastic bottle counts!



CONDICIONES, GARANTÍAS Y MANTENIMIENTO CONDITIONS, GUARANTEE AND MAINTENANCE

FM ILUMINACION, S.L.U. se reserva el derecho de efectuar modificaciones en los modelos del presente catálogo, con el fin de mejorar sus características de diseño, su seguridad o sus funciones lumino-técnicas.

F.M ILUMINACIÓN, S.L.U. reserves the right to make any changes it believes are beneficial to the products of the present catalogue, with the aim to improve the characteristics, safety or lighting applications.

GARANTÍA/ GUARANTEE

El fabricante entrega junto a los equipos una garantía que asegura el correcto funcionamiento del equipo y posibles reparaciones o suministro de recambios del modelo debidos a defectos de fabricación durante 3 años desde la fecha de entrega. Se excluyen consumibles como bombillas, etc, que será de 2 años.

Manufacturer guarantees the proper functioning of this equipment, repairs or spare parts of the model owing to faulty manufacture during 3 years after the surrender date. Responsibility will not be accepted, however, for damages or injury caused through misuse.

SELLOS DE CALIDAD Y RESPONSABILIDAD SOCIAL CORPORATIVA QUALITY GUARANTEE AND CORPORATE SOCIAL RESPONSIBILITY

Nuestro objetivo es proporcionar la mejor calidad tanto a nuestros productos como a nuestros servicios, intentando conseguir la máxima satisfacción al cliente, nos avalan los sellos de calidad AENOR. Nuestra Responsabilidad Social Corporativa está basada en la contribución activa y voluntaria al mejoramiento social, económico y ambiental para lo cual colaboramos con ONGs algunas de reconocido prestigio como son con Médicos del Mundo e Intermon Oxfam y otras que hacen una labor más modesta pero importante, como es Creer en ellas, que busca dar respuesta a una realidad cotidiana de violencia y vulnerabilidad que sufren jóvenes y adolescentes en la R.D del Congo. Nuestro equipo humano trabaja con el máximo respeto hacia el medioambiente, mejorando nuestros procesos productivos con ese fin y, sobre todo, promovemos el ahorro energético. Es nuestro compromiso con una sólida ética laboral, integridad y honestidad.

Our aim is to provide the best quality both to our products and our services, trying to achieve maximum customer satisfaction, this objective is backed by AENOR and its quality stamps we have got. Our Corporate Social Responsibility is based on the active and voluntary contribution to social, economic and environmental improvement for which we collaborate with prestigious NGOs such as Doctors of the Word and Intermon Oxfam and others that do a more modest but important work, such as "Creer en ellas", which seeks to respond to a daily reality of violence and vulnerability suffered by young women and adolescents in the D.R. Congo. Our human team is working with the highest respect for the environment, improving our production processes and above all we promote energy saving. It's our commitment to a solid work ethic, integrity and honesty.





Gracias por confiar en Ole! Lighting
Thank you for trusting Ole! Lighting

*- Fernando Martínez
(Owner and Head of Design)*

AGRADECIMIENTOS / *CREDITS*

Fotografía/ *Photos:*
Juanjo Aviñó | Studios Aviñó
Pablo Vicent | AGV Comunicación

Imprenta/ *Printed by:*
Mundo Gráfico

Copyright: © copyright - FM Iluminación S.L.U -2023



FM Iluminación S.L.U

www.ole-lighting.com

C/ Germanías, 12-14, Pol. Ind "El Pou"

46960 Aldaia, Valencia, SPAIN

T.+34 961 515 977

F.+34 961 516 290

info@ole-lighting.com

Direct Export

Tel: +34 655 917 238

export@ole-lighting.com

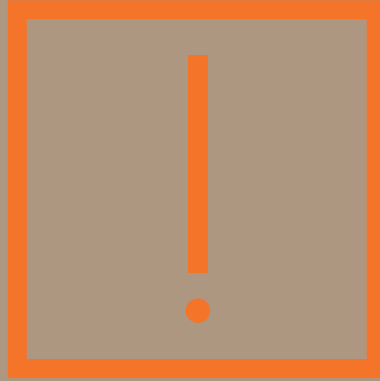

www.ole-lighting.com

FM Iluminación S.L.U

www.ole-lighting.com

C/ Germanías, 12-14, Pol. Ind "El Pou"

46960 Aldaia, Valencia, SPAIN

T.+34 961 515 977

F.+34 961 516 290

info@ole-lighting.com

Whatsapp: +34 657 979 510

Direct Export

Tel: +34 655 917 238

export@ole-lighting.com