



B201

Light
and space

Compab 2021

Light & Space

L'armonia degli spazi.

Light & Space

The harmony of open spaces.



Nel pensiero orientale, la categoria estetica per eccellenza è il *ma*. Il Vuoto.

In Occidente il pensiero greco ha imposto l'idea del vuoto come assenza, privazione, negazione (dal latino *nihil*). Il vuoto è causa della sensazione dell'*horror vacui*. Il vuoto fa paura.

Al contrario, nelle culture orientali il vuoto è sinonimo di infinite possibilità, di massima apertura e libertà: significa spazio, e lo spazio è la condizione essenziale affinché ogni fenomeno, ogni cosa possa esistere e operare ("vuoto utile"). Il vuoto è l'inizio.

“Una stanza immaginaria che si trova in una posizione indefinita tra il cielo e la terra, si dice sia il modo originario per rappresentare il concetto di ma.”

Sachiyo Goda, An Investigation into the Japanese Notion of 'ma': Practising Sculpture Within Space-Time Dialogues.

Nel design moderno, lo spazio vuoto è importante quanto lo spazio pieno: anche il vuoto occupa un suo spazio ed è percepito come una presenza. Gli opposti come il bianco e il nero, la luce e l'ombra, il vuoto e il pieno si completano a vicenda e non possono esistere l'uno senza l'altro.

L'opposizione vuoto-pieno diventa un'entità vivente e dinamica. Si fondono in un equilibrio armonioso che dà forza ed energia.

Per ritrovare equilibrio e armonia nel nostro bagno, la relazione tra spazio vuoto e spazio pieno vibra in una danza armonica, i cui protagonisti sono gli elementi che scegliamo per arredarlo.

According to Oriental philosophy, the most valued aesthetic characteristic is "*ma*". Emptiness.

In the West, Greek philosophy developed the concept of emptiness as absence, privation, negation (from the Latin "*nihil*"). The emptiness is created by "*horror vacui*" – the fear of empty space. Empty space creates fear.

At the other end of the spectrum, in Oriental cultures, emptiness is a synonym of infinite possibilities, of maximum aperture and freedom: it signifies space, and space is the condition which is essential in ensuring that every phenomenon and every thing can exist and be "useful space". Emptiness is the beginning.

“An imagined room positioned uncertainly between heaven and earth is said to be the original way of picturing the concept of ma.”

Sachiyo Goda, An Investigation into the Japanese Notion of 'ma': Practising Sculpture Within Space-Time Dialogues.

In modern design, empty space is equally important as closed space: empty space, too, is perceived as a presence. Opposites such as black and white, light and shade, empty and full complete the overall image; one cannot exist without the other.

The juxtaposition of empty and full becomes a living and dynamic entity, blending together in a harmonious equilibrium which creates force and energy.

If we are to create equilibrium and harmony in our bathroom, the relationship between empty space and full space must vibrate in a harmonic dance in which the protagonists are the elements that we choose for furnishing it.

B201

Light and space

Compab 2021

BD002





↑ Resistenza e durata del piano con vasca integrata sono garantiti dalla scelta del gres.

The use of porcelain stoneware ensures that the top with its built-in sink will last for a lifetime.

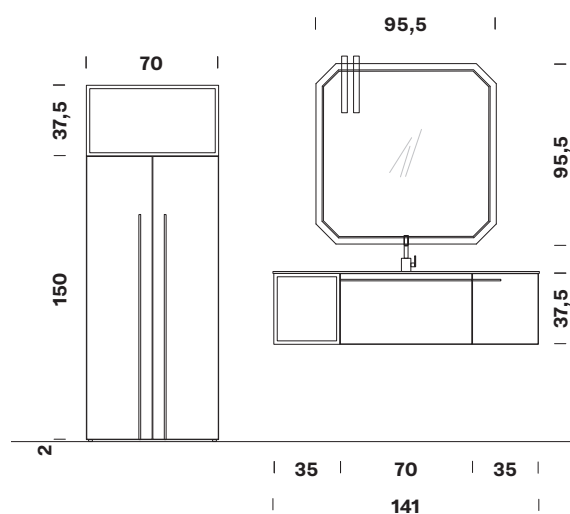

Scocca e frontali: 268 cross nobilitato
 Piano con vasca integrata "Club 45" in gres sp. 1,3 cm, vasca piccola, finitura 22 Iseo
 L 70+141 x P 37/46 cm

Structure and doors: 268 cross melamine
 "Club 45" top with integrated basin in gres 1.3 cm th., small basin, "22 Iseo" finish
 W 70+141 x D 37/46 cm





↑ Perfetto equilibrio tra classico e moderno: la cornice in alluminio dà un tocco contemporaneo allo specchio dalla forma retrò.

A perfect balance of classic and modern: the aluminium frame gives the retro mirror a modern look.





BD028



↑ Morbidezza e sinuosità. La linea morbida del lavabo è in perfetta armonia con la linea flessuosa del mobile che lo sostiene.

Soft and sinuous lines. The gently-shaped lines of the basin are a perfect match for the clean and simple lines of the supporting cabinet.

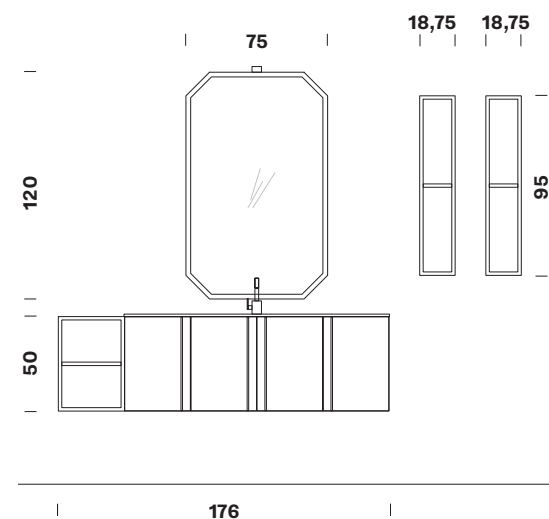

Scocca e frontali: 111 bianco lucido
 Lavabo consolle "Versus" in Mineralguss bianco lucido
 L 141 cm
 L 176+18,75+18,75 x P 20,8/51/15 cm

Structure and doors: 111 glossy white
 "Versus" console washbasin in glossy white Mineralguss
 W 141 cm
 W 176+18.75+18.75 x D 20.8/51/15 cm

↙ Per impreziosire la schiena degli elementi a giorno viene proposta una finitura marmo.

The marble finish enhances the look of the rear panel of the open-fronted compartments.



→ Le maniglie disposte in verticale seguono naturalmente le linee ammorbidite del mobile, in cui si integrano perfettamente.

The vertical position of the handles are the natural complement to the soft lines of the cabinet.

Compab → B201

BD001



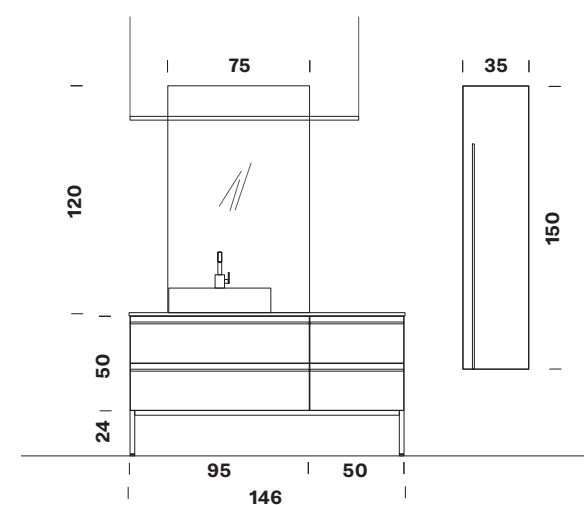

Scocca e frontali: 940 laccato sabbato (N1 nuvola)

Lavabo tutt fuori "Lisbona" in stratificato HPL (3Q Statuario)

Piano in stratificato HPL (3Q Statuario) sp. 1 cm

L 146+35 x P 51/20,8 cm

Structure and doors: 940 embossed lacquered (N1 nuvola)

"Lisbona" outside washbasin in HPL (3Q Statuario)

Top in HPL (3Q Statuario) 1 cm th.
W 146+35 x D 51/20.8 cm

↓ Soluzione raffinata e di grande effetto quella del piano e del lavabo realizzati nello stesso materiale (stratificato HPL).

This top and sink, created using the same material (laminated HPL), is a refined and eye-catching solution.



→ Grazie alla texture leggera, i cassetti si accompagnano perfettamente al piano e donano grazia all'intero mobile.

Thanks to their light texture, the drawers are perfectly matched with the top, and help give the entire unit its attractive look.





BD006

B201 → BD006



↑ Inalterabile e resistente il piano in gres sottile, che imita perfettamente il marmo.

The top in thin stoneware is tough and durable, and is a perfect imitation of real marble.

Scocca e frontali: 270 reflex perla nobilitato
Lavabi tuttofuori "Cognac 42" in ceramica
Piano in gres sp. 1,3 cm, finitura 23 Amani
L 191 x P 51 cm

Structure and doors: 270 reflex perla melamine
"Cognac 42" outside washbasins in ceramic
Top in gres 1.3 cm th., "23 Amani" finish
W 191 x D 51 cm

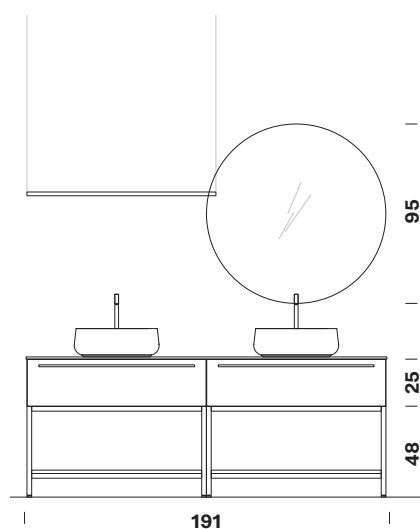



← Una soluzione moderna in alluminio spazzolato con ripiano in legno, completa di cassetto per riporre gli oggetti più piccoli.

A modern design in brushed aluminium with wooden shelves, complete with drawers to keep smaller items tidy.



Il bello funzionale.

Un oggetto, per essere “bello”, deve essere funzionale e soddisfare anche un bisogno estetico.

“Ogni idea è già un'azione, ed ogni azione possiede in sé energia e valore spirituali.”

Cit. da Estetica del vuoto - Arte e meditazione nelle culture d'Oriente

Siamo sempre stati abituati a considerare la teoria e la pratica come due concetti ben distinti, ma l'approccio del design e dell'architettura contemporanea si basa sull'idea che non c'è una separazione netta tra teoria e pratica. L'estetica è considerata parte integrante della vita quotidiana, del dialogo tra l'uomo, gli oggetti e gli spazi. Parlare dunque di “estetica” come “scienza del bello”, come contemplazione di un'idea metafisica non ha significato secondo questo orizzonte.

Il “bello” è sempre rapportato a una situazione concreta, è l'esperienza di qualcosa che funziona e che quindi appaga il senso estetico: non c'è separazione tra bello e funzionale, tra l'estetica e la funzione di un oggetto.

Functional beauty.

If any object is to be perceived as "beautiful", it must be functional and at the same time must meet an aesthetic need.

“Every idea is an action in itself, and every action encompasses spiritual energy and value.”

Cit. from "Estetica del vuoto - Arte e meditazione nelle culture d'Oriente"

We have always been accustomed to consider theory and practise as two very different concepts, but the approach adopted by contemporary design and architecture is based on the idea that there is no real distinction between the two. Aesthetics are considered as an integral part of daily life, dialogue between man, objects and spaces. Thus any discussion of "aesthetics" and "the science of beauty" as a contemplation of a metaphysical concept has no meaning in this respect.

What is "beautiful" refers in every case to a concrete situation; it is the experience of something which functions correctly and thus satisfies the aesthetic senses: there is no separation between what is beautiful and what is functional, nor between the aesthetic value and the functionality of an object.



BD018



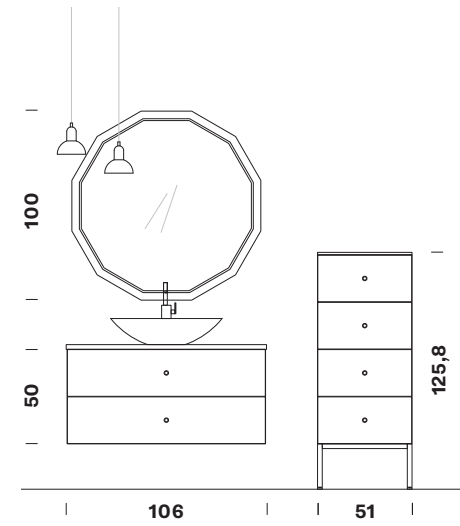

Scocca e frontali: 290 Cross
laccato opaco (H5 datura)
Piano e lavabo "Roly"
in ceramica L 106 cm
L 106+51 x P 46,5/37 cm

Structure and doors: 290 Cross
matt lacquered (H5 datura)
Top and washbasin "Roly"
in ceramic W 106 cm
W 106+51 x D 46.5/37 cm



← Il "Cross" è un materiale
dalla trama in legno accentuata,
proposto in versione colorata.
La nuance scelta è tenue
e delicata.

"Cross" is a material with
a marked wood grain,
available in a range of colours.
The distinction is subtle
and delicate.



← Si chiama "Omega 1" la specchiera in alluminio spazzolato che ha la forma di una figura geometrica perfetta: il dodecaedro.

The "Omega 1" mirror is in brushed aluminium with a perfectly geometrical shape: the dodecahedron.



→ Design classico e stile moderno per "Lamda", la lampada a sospensione che piace per la trasparenza e per l'effetto intenso dell'insieme.

Classic design and modern styling for "Lamda", a suspended lighting unit whose transparency, together with attractive design, is truly eye-catching.



Compab → B201

BD025





→ Raffinatezza senza tempo. La delicatezza viene conferita ad un mobile dalla sinuosità delle ante ed esaltata dalla scelta di una laccatura metallizzata.

Refinement which is timeless. The cabinet's delicate lines are emphasized by the sinuous shape of the doors and underlined by the metallic lacquer finish.





→ L'ovale morbido dello specchio segue perfettamente le linee sinuose del mobile.

The softly-rounded oval shape is the perfect complement to the sinuous lines of the cabinet.

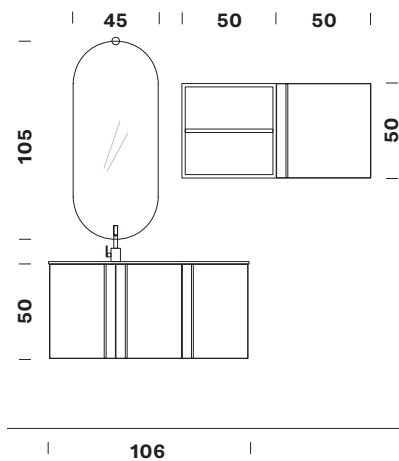

Scocca e frontali: 900 laccato opaco (F3 petalo, D1 malva)
Lavabo consolle "Versus" in Mineralguss
L 106+100 x P 51/20,8 cm

Structure and doors: 900 matt lacquered (F3 petalo, D1 malva)
"Versus" console washbasin in Mineralguss
W 106+100 x D 51/20.8 cm







BD015



Scocca e frontali: 291 Reflex laccato opaco
(H4 cameo)
Lavabo consolle "Tempo" in ceramica L 96 cm
L 96+71 x P 46,5/46 cm

Structure and doors: 291 reflex matt lacquered
(H4 cameo)
"Tempo" console washbasin in ceramic W 96 cm
W 96+71 x D 46.5/46 cm

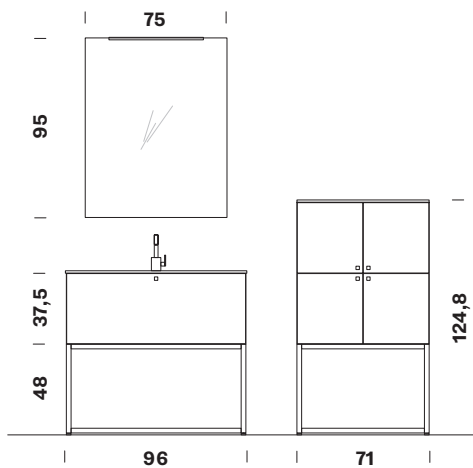

↑ Delicato e tenue il cassetto color "cameo" con trama rigata
ma sottile, che richiama l'effetto spazzolato dell'acciaio.

The delicate, pale "cameo" finish on the drawer, with its
thin stripes, is reminiscent of a brushed steel finish.



← I dettagli in alluminio spazzolato impreziosiscono la madia (o oggetto totem) e i pomoli quadrati la completano. Il ripiano in vetro è rimovibile.

The appearance of the cupboard is enhanced by elements in brushed aluminium and completed by the square-shaped knobs. The glass shelf is removable.



BD017

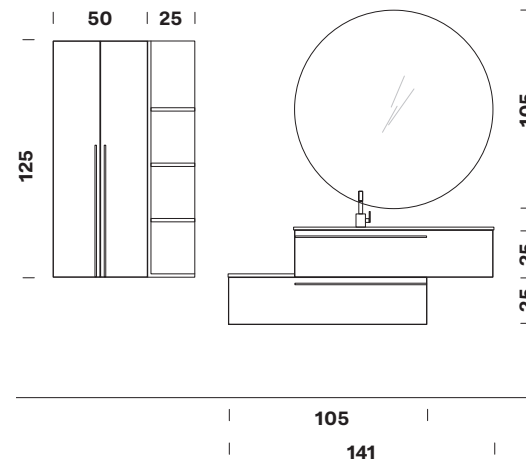
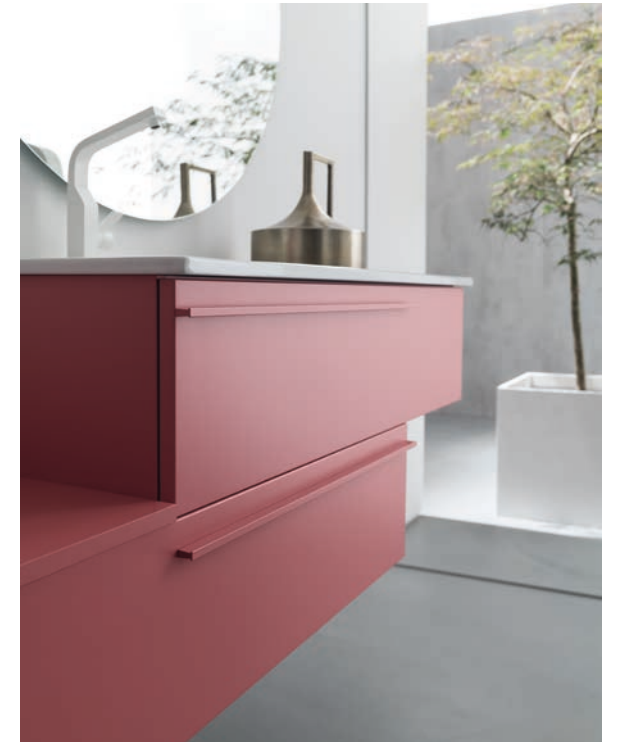

Scocca e frontali: 900 laccato opaco (H3 peonia)
 Lavabo consolle "Milk" in ceramica L 106,5 cm
 L 75+141 x P 20,8/51,5 cm

Structure and doors: 900 matt lacquered (H3 peonia)
 "Milk" console washbasin in ceramic W 106.5 cm
 W 75+141 x D 20.8/51.5 cm

↑ Mimetismo (quasi) perfetto.
 Le maniglie accompagnano lo sviluppo orizzontale del mobile passando quasi inosservate.

Perfect camouflage (well, almost).
 The handles are aligned with the horizontal lines of the cabinet while at the same time merging into the overall colour and becoming almost unnoticeable.

BD013





→ Eleganza e stile di un mobile dalla trama che ricorda un abito gessato. Anche le maniglie seguono la riga ed il colore del mobile.

The elegant and stylish cabinet is reminiscent of a chalk-stripe suit. The handles, too, are coordinated with the stripes and colours of the cabinet.

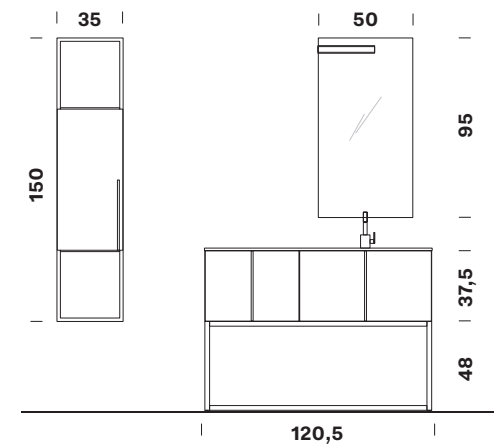

Scocca e frontali: 292 Laos laccato opaco (H7 infinity)
Lavabo consolle "Style" in Mineralguss bianco opaco L 120,5 cm
L 35+120,5 x P 20,8/51,5 cm

Structure and doors: 292 Laos matt lacquered (H7 infinity)
"Style" console washbasin in matt white Mineralguss W 120.5 cm
W 35+120.5 x D 20.8/51.5 cm





BD016





← Funzionalità e efficacia per la maniglia in acciaio zigrinato che, all'occorrenza, può essere utilizzata come portasalviette.

The functional handle in knurled steel can also be used as a tea-towel holder.

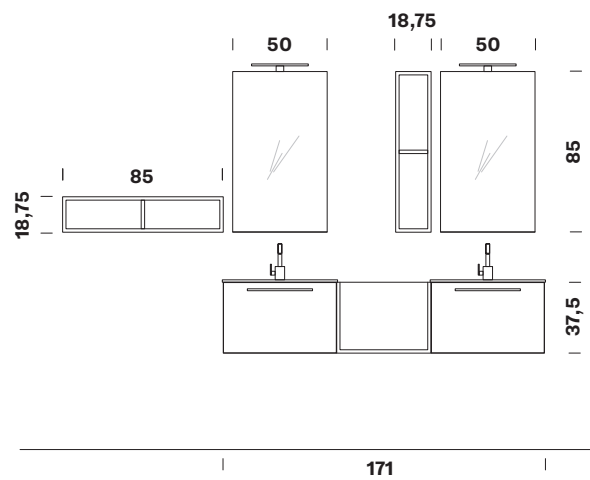

Scocca e frontali: 900 laccato opaco (H6 jasmine)
 Lavabi consolle "Ora" in Mineralguss bianco
 lucido L 60,5 cm
 L 85+171 x P 15/46 cm

Structure and doors: 900 matt lacquered
 (H6 jasmine)
 "Ora" console washbasins in glossy
 white Mineralguss W 60.5 cm
 W 85+171 x D 15/46 cm



← L'importanza della luce. Semplice ed
 essenziale, il faretto TAU presenta
 una parte in metacrilato che permette
 un'ottima fuoriuscita della luce a led.

The importance of light. The design of the
 TAU spotlight is simple and essential, with
 a section in methacrylate to enhance the
 light produced by the LED lamp.

BD014



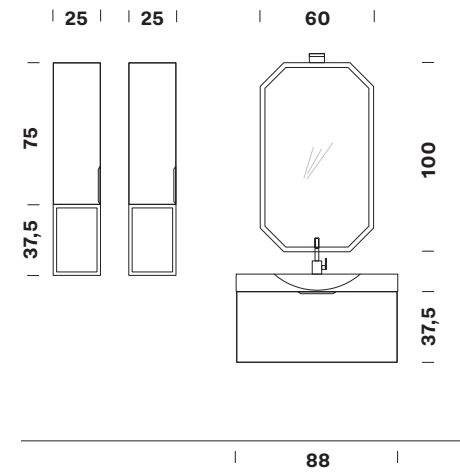

Scocca: 940 laccato sabbato (N4 tormalina) e 111 bianco lucido
 Frontali: 940 laccato sabbato (N4 tormalina)
 Lavabo consolle "Zara" in ceramica L 88 cm
 L 25+25+88 x P 20,8/38,5/46 cm

Structure: 940 matt embossed (N4 tormalina) and 111 glossy white
 Doors: 940 matt embossed (N4 tormalina)
 "Zara" console washbasin in ceramic W 88 cm
 W 25+25+88 x D 20.8/38.5/46 cm

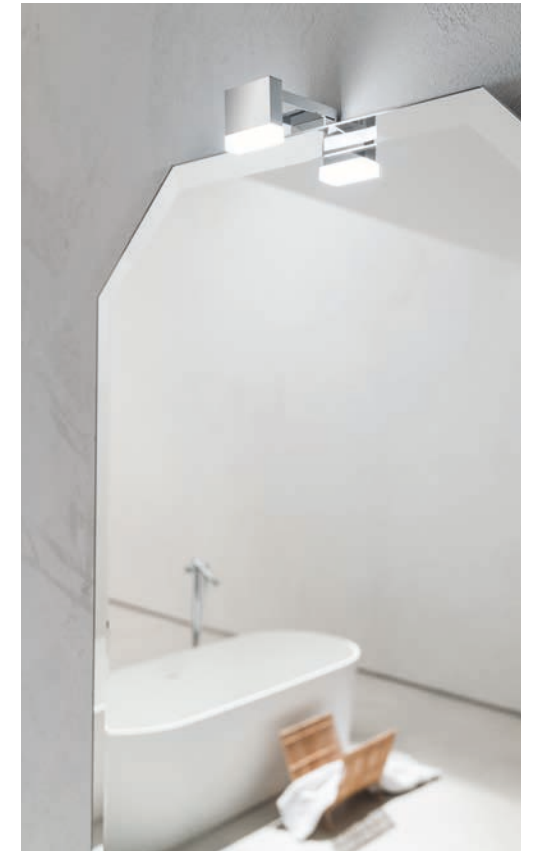

→ Un'ottima soluzione salvaspazio.
 La parte laterale del lavabo
 "Zara" misura appena 38,5 cm di
 profondità.

A super-space-saving idea.
 The lateral section of the "Zara"
 basin unit is just 38.5 cm in depth.

← Il colore laccato e acceso di
 questo mobile ha una trama
 particolare che conferisce
 l'effetto "pittura murale".

The bright lacquer colour of this
 cabinet features an unusual
 texture which reproduces the
 effect of a mural painting.





In armonia con la Natura.

L'apertura degli spazi verso l'esterno è ricerca di un rapporto privilegiato con la Natura. Anche i ritmi stagionali di luce e crepuscolo si riflettono sugli spazi interni degli ambienti.

Il bisogno dell'uomo di mantenere una connessione vitale con la propria essenza lo spinge alla ricerca di riprodurre gli elementi della Natura negli ambienti e negli spazi in cui abita.

Alcuni aspetti che ritroviamo nell'architettura e nel design sono sempre più riconducibili a principi matematici ispirati dalla natura: le proporzioni, il ritmo tra gli elementi, ma anche il rapporto aureo, la sequenza dei numeri di Fibonacci, etc.

Questi elementi, che esistono nella Natura, soddisfano il nostro bisogno estetico in quanto siamo abituati da sempre a percepirli come armoniosi.

Studiare questi principi e portarli nel design e nell'architettura significa riproporre la stessa armonia nell'ambiente in cui viviamo.

Ancora una volta spazio esterno e spazio interno si incontrano in armonia, osservando e riproponendo le leggi della Natura.

In harmony with Nature.

To open spaces towards the outside is to seek a special relationship with Nature.

At the same time, the seasonal alternating of light and dark reflect upon the internal spaces of a room.

Man's need to maintain a vital connection with his essence leads him to attempt to reproduce Nature's elements in furnishing and in the spaces where he lives.

Certain aspects that we find in architecture and design are increasingly linked to mathematical principles inspired by Nature: proportions, the rhythms of the various elements, but also to the golden ratio, the Fibonacci sequence etc.

These elements, which exist in Nature, meet our aesthetic needs because we are accustomed to perceiving them as harmonious.

To study these principles and to apply them to design and architecture means reproducing the same harmony to be found in the ambient in which we live.

Once again, external space and internal space meet in harmony, observing and reproducing the laws of Nature.



BD005



↑ Capienza e funzionalità sono assicurate dalla forma di questo lavabo, realizzato in ceramica.

The shape of this ceramic basin is designed for maximum capacity and functionality.

→ C'è ma non si vede!
Il contenitore laterale a giorno è studiato per sfruttare lo spazio, senza disturbare.

You can't see it, but it's there!
The open-fronted lateral container is designed to make the best use of available space but without getting in the way.



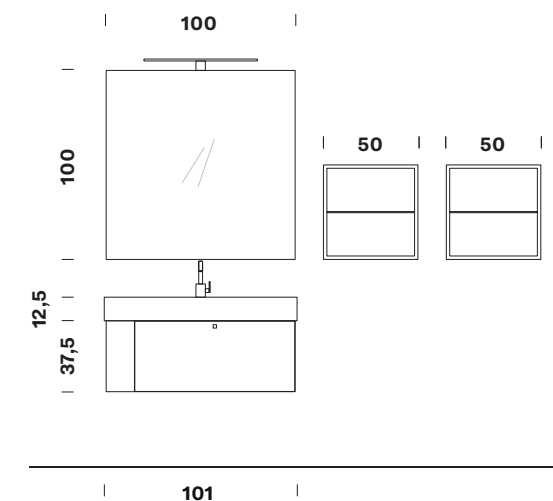

Scocca e frontali:
210 Seta nobilitato
Lavabo consolle "Elegance"
in ceramica L 101 cm
L 101+50+50 x P 46,5/20,8 cm

Structure and doors:
210 "Seta" melamine
"Elegance" console washbasin
in ceramic W 101 cm
W 101+50+50 x D 46.5/20.8 cm

BD021





↓ Una soluzione perfetta quando si è alle prese con spazi contenuti. Il lavabo ha una profondità minima, ma il mobile non rinuncia ai cassetti per contenere gli oggetti.

The perfect solution when space is at a premium. The depth of the basin is reduced, but the cabinet still features spacious drawers for so many everyday items.

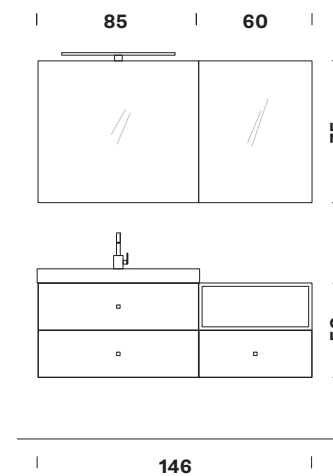

Scocca e frontali: 263 Reno nobilitato
Lavabo consolle "Set up" in ceramica L 86,5 cm
L 146 x P 40/15 cm

Structure and doors: 263 "Reno" melamine
"Set up" console washbasin in ceramic W 86.5 cm
W 146 x D 40/15 cm



BD026

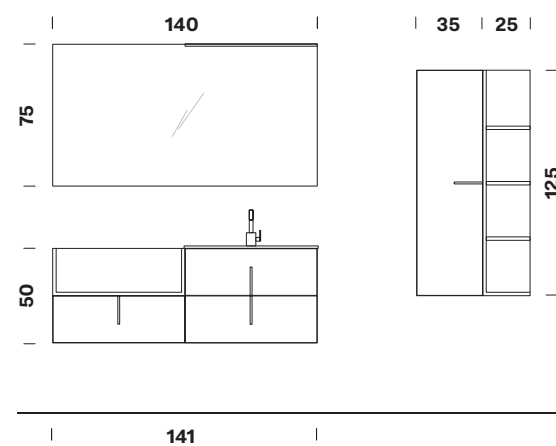

Scocca e frontali: 110 bianco opaco
e 275 Evoke nobilitati
Lavabo consolle "Versus" in
Mineralguss bianco lucido L 71 cm
L 141+60 x P 37/51/20,8 cm

Structure and doors: 110 matt
white and 275 "Evoke" melamine
"Versus" console washbasin in
glossy white Mineralguss W 71 cm
W 141+60 x D 37/51/20.8 cm

↑ Spazi aperti e spazi chiusi, a
contrasto. Un vano in finitura
legno spicca sul mobile bianco e
permette di avere alcuni oggetti a
portata di mano.

Open and closed spaces form an
attractive contrast. The wood-
finish compartment contrasts the
white cabinet and provides space
for those everyday items.



↑ L'illuminazione diffusa viene offerta e garantita da una barra luminosa posizionata sopra lo specchio.

A light bar positioned above the mirror provides plenty of light.

BD010





← Legno o effetto legno?
Il nuovo materiale del frontale "kiki" imita perfettamente il legno di rovere, nodi e venature compresi.

Real or imitation wood?
The new material used for the "kiki" front panel is a perfect imitation of oak, including knots and an attractive grain.





← Oggetti a vista o nascosti?
 Questi contenitori permettono
 entrambe le soluzioni, sono
 proposti sia con che senza ante.

Items on view or stored away?
 These containers provide either
 solution and are available with or
 without doors.



Scocca: 276 Kiki nobilitato e 900
 laccato opaco (M2 cactus)
 Frontali: 276 Kiki nobilitato
 Lavabo tuttofuori "Soap" in ceramica
 Piano in Mineralguss sp. 1,3 cm
 L 96+35+35 x P 51/20,8 cm

Structure: 276 Kiki melamine and
 900 matt lacquered (M2 cactus)
 Doors: 276 Kiki melamine
 "Soap" outside washbasin in ceramic
 Top in Mineralguss 1.3 cm th.
 W 96+35+35 x D 51/20.8 cm

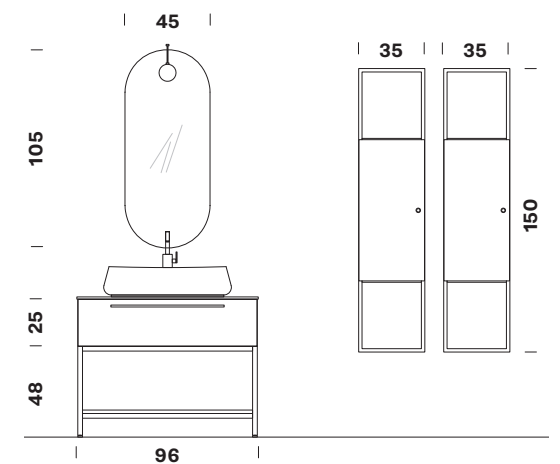



BD022



← Armonia e benessere. Il lavabo e il piano sono realizzati nello stesso materiale simil pietra. Il risultato è una perfetta integrazione.

Harmony and wellbeing. The basin and the top are in a matching stoneware-effect finish. The result? Perfect integration.

Scocca e frontali: 263 Reno nobilitato
 Lavabo tutt'fuori "Lisbona" in stratificato
 HPL (3V Aniene)
 Piano in stratificato HPL (3V Aniene) sp. 1 cm
 L 125,3+105 x P 46/20,8 cm

Structure and doors: 263 "Reno" melamine
 "Lisbona" outside washbasin in HPL
 (3V Aniene)
 Top in HPL (3V Aniene) 1 cm th.
 W 125.3+105 x D 46/20.8 cm

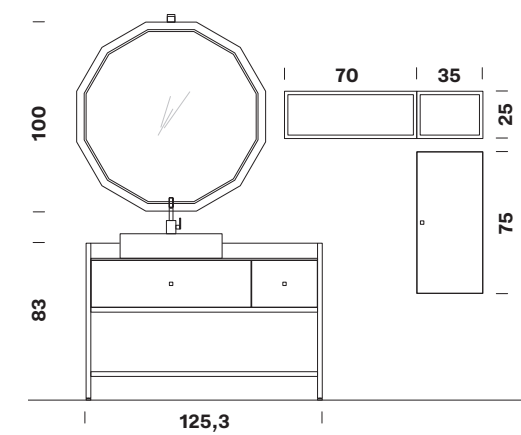



← Essenziale e funzionale. La struttura in alluminio spazzolato offre ripiani portaoggetti di uso immediato, portasalviette laterale e cassetti contenitori.

An essential and functional design. The structure in brushed aluminium features shelves for smaller everyday items, lateral towel rails and spacious drawers.



Compab → B201

BD024





→ Essenziale e funzionale. Pur avendo la forma di un piccolo cubo, questo pomolo permette una facile apertura dell'anta.

Essential, functional design. Although shaped as a small cube, this knob opens the door with the greatest of ease.



Scocca e frontali: 275 Evoke nobilitato
Lavabo consolle "Tempo" in ceramica L 121,5 cm,
doppia vasca
L 65+121,5 x P 20,8/46,5 cm

Structure and doors: 275 "Evoke" melamine
"Tempo" console washbasin in ceramic W 121.5 cm,
double basin
W 65+121.5 x D 20.8/46.5 cm

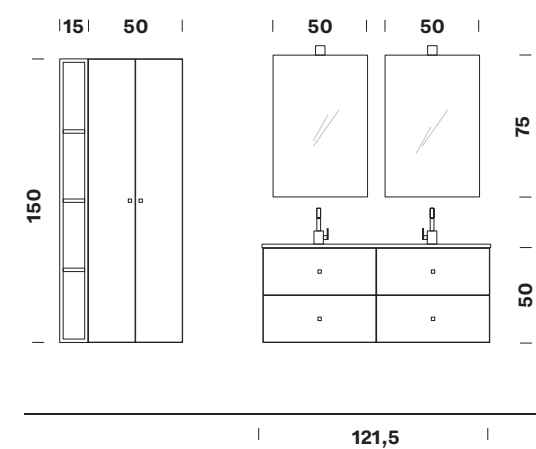

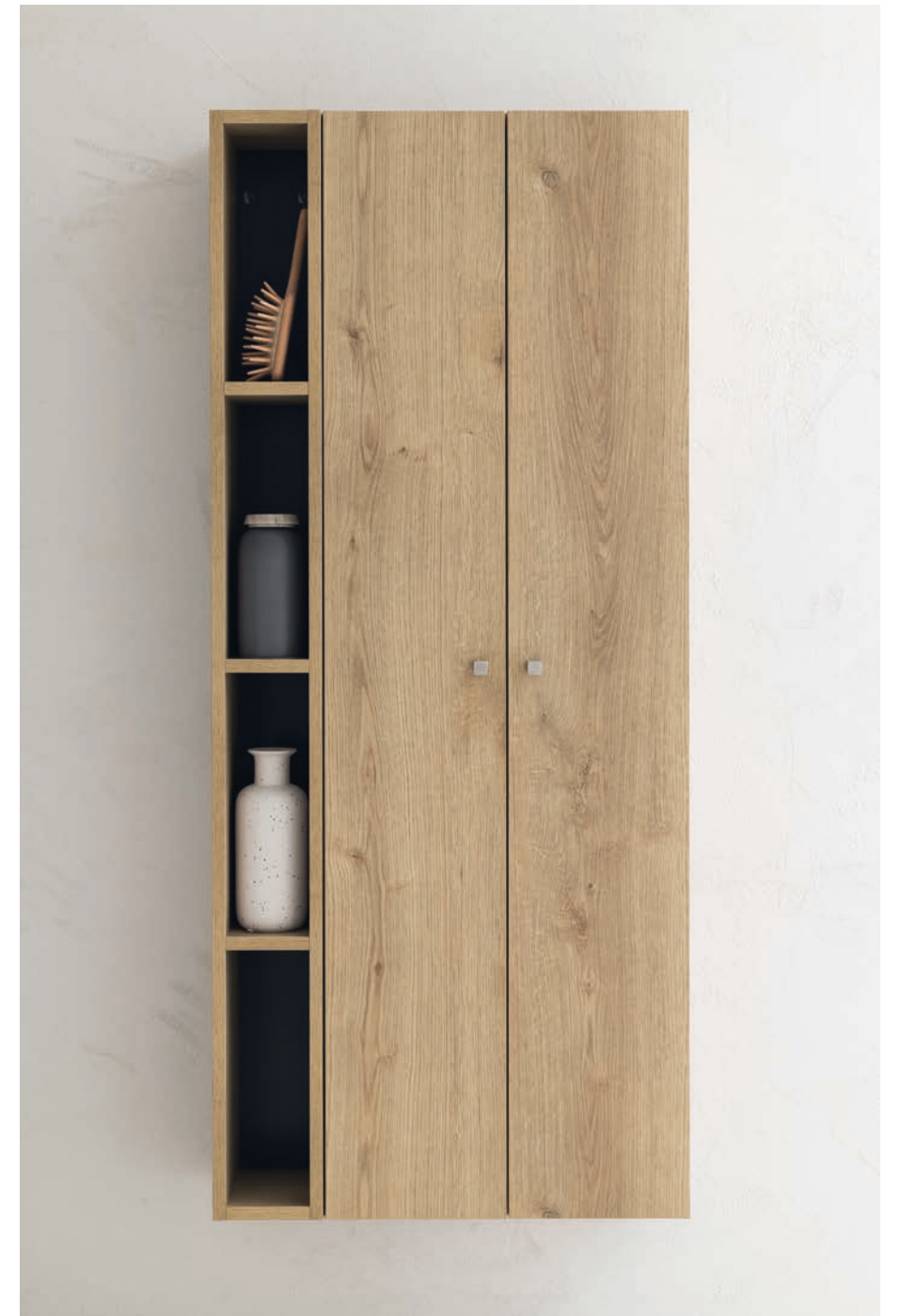

← Sfruttare uno spazio in modo intelligente per un doppio utilizzo. Il doppio lavabo in ceramica diventa più comodo per due.

Intelligent use of space to give dual access. The double ceramic basin is the ideal solution for a couple.



BD023

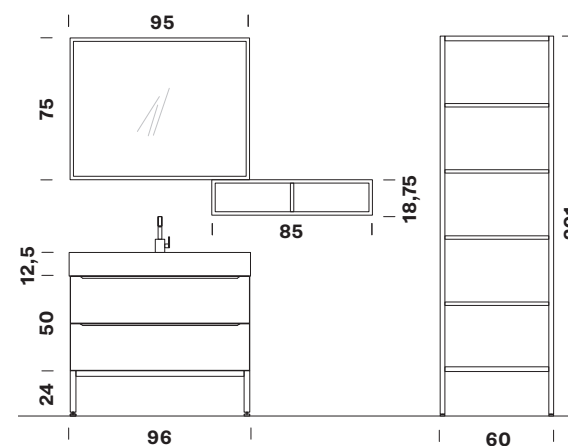

Scocca e frontali: 275 Evoke nobilitato
 Lavabo consolle "Elegance" in ceramica L 96 cm
 L 96+85+60 x P 46,5/15/50 cm

Structure and doors: 275 "Evoke" melamine
 "Elegance" console washbasin in ceramic W 96 cm
 W 96+85+60 x D 46.5/15/50 cm



← La specchiera rettangolare è pratica e funzionale. Coniuga la necessità di garantire una perfetta illuminazione e uno spazio di appoggio, come la mensola.

The rectangular mirror is practical and highly functional, combining the needs for perfect lighting and handy storage space on the shelf.



↑ La praticità di una maniglia orizzontale che permette una facile presa ed agevola l'apertura del cassetto.

The practical horizontal handle is easy to grip and makes opening the drawer even more simple.

→ Spazio, luce e leggerezza. Questi gli elementi chiave della struttura a giorno in alluminio nero, con ripiani in legno che si abbinano al mobile portalavabo.

Space, light and attractive, light design. These are the key elements of the open-front structure in black aluminium, designed to coordinate with the basin cabinet.



Lo spazio svelato dalla luce.

La luce è energia, è fonte primaria di vita.

Il colore della luce è importante perché rappresenta l'assenza di impurità. Il bianco, oltre ad indicare limpidezza e chiarezza, rimanda a qualcosa di positivo, di distinto, di puro.

Uno dei cardini dell'architettura moderna è il rapporto luce - spazio architettonico, sia nella risoluzione degli interni che degli esterni. La luce solare invade lo spazio interno e modella l'ambiente e i suoi arredi: l'interno e l'esterno si fondono senza una netta distinzione.

La luce ha la capacità di creare lo spazio architettonico rivelandone l'essenza.

Space is revealed by light.

Light is energy, the essential source of life.

The colour of light is important because it represents the absence of impurities. White, as well as implying clarity and purity, suggests something that is positive, distinctive and pure.

One of the linchpins of modern architecture is the relationship between light and space, whether in interior or exterior settings. The light of the sun pervades the interior space, modelling the ambient and its furnishings: interior and exterior blend together without any net distinction.

Light has the ability to create the architectural space, thus revealing its essence.



Compab → B201

BD007





← Un colore splendido per il piano con vasca integrata in Corian; il grigio scuro si integra perfettamente nell'insieme.

This top with built-in Corian basin is in an eye-catching colour, while the dark grey is the perfect complement for the unit.

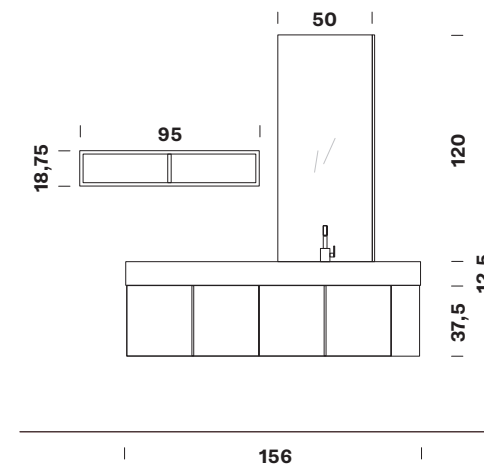

Scocca e frontali: 262 Ghadira nobilitato
Piano con vasca integrata "Enigma" in Corian
sp. 12,5 cm, vasca piccola, finitura deep cloud
L 95+156 x P 51/15 cm

Structure and doors: 262 "Ghadira" melamine
"Enigma" top with integrated basin in Corian
12.5 cm th., small basin, "deep cloud" finish
W 95+156 x D 51/15 cm





BD029



↑ La finitura opaca e la capienza caratterizzano il lavabo, trasformandolo in un elemento importante del bagno.

The basin is characterized by its opaque finish and large dimensions, and becomes an eye-catching part of the bathroom.

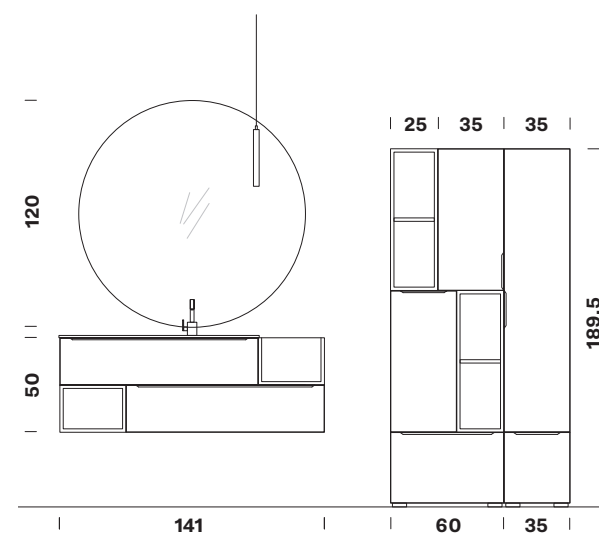

Scocca e frontali:
292 Laos laccato opaco (K1 bianco)
Lavabo consolle "Style"
in Mineralguss bianco opaco L 105,5 cm
L 141+95 x P 51,5/37 cm

Structure and doors:
292 Laos matt lacquered (K1 bianco)
"Style" console washbasin
in Mineralguss matt white W 105.5 cm
W 141+95 x D 51.5/37 cm



← Una soluzione elegante e raffinata per garantire la diffusione perfetta della luce. La lampada sospesa ha la forma di un sottile cilindro luminoso di vetro.

Refined and elegant design provides perfect diffusion of the light. The overhead lamp is shaped like a slim and bright glass cylinder.



← L'alternanza di vani chiusi e vani a giorno attribuisce al mobile dinamicità e praticità, ed unisce funzionalità e leggerezza.

The juxtaposition of closed and open compartments gives this cabinet its dynamic and practical look, combining functionality with elegant lines.

→ L'eleganza viene assicurata dalla texture a righe bianche, mentre le maniglie disegnano un contrasto di colore nero.

The textured white lines are a truly elegant touch, while the black handles provide an eye-catching contrast.



BD003





↑ Resistente e sottile, il piano in gres in finitura "Piase" sostiene un robusto lavabo in ceramica.

Tough but thin, the stoneware top in a "Piase" finish supports a sturdy ceramic sink.

← Quando il bello è funzionale. L'elegante struttura in alluminio nero è dotata di un vano sottostante con ripiano in vetro grigio rimovibile e di facile pulizia, per collocare oggetti sempre pronti all'uso.

When attractive design and functionality company together. The elegant structure in black aluminium features a removable and easy to clean compartment in grey glass in which to place frequently-used items.



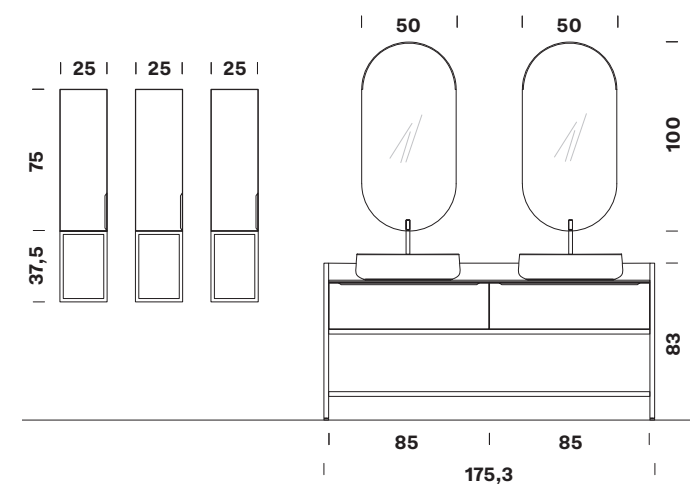

Scocca e frontali: 110 bianco opaco nobilitato
 Lavabi tuttofuori "Cognac 55" in ceramica
 Piano in gres sp. 1,3 cm, finitura 24 Piase
 L 25+25+25+175,3 x P 20,8/46 cm

Structure and doors: 110 matt white melamine
 "Cognac 55" outside washbasins in ceramic
 Top in gres 1.3 cm th., "24 Piase" finish
 W 25+25+25+175.3 x D 20.8/46 cm

← Uno specchio di stile. La leggerezza del telaio in metallo nero confluisce, nella parte superiore, con un'illuminazione integrata a Led.

A truly stylish mirror. The upper section of the slim frame in black metal houses an integrated LED lamp.



BD004



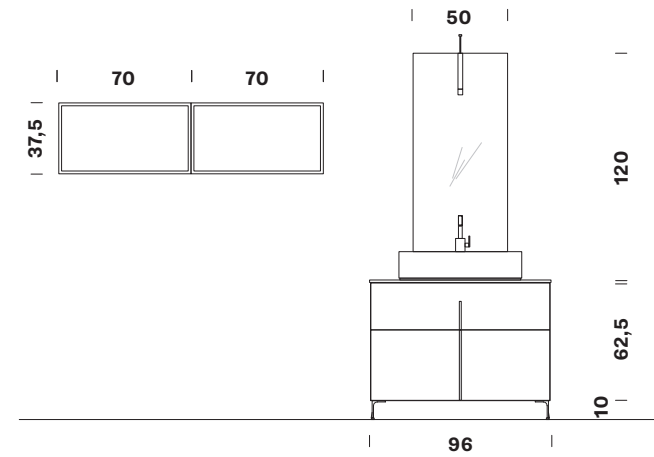

Scocca e frontali: 270 reflex perla nobilitato
 Lavabo tuttofuori "Couture" in Mineralguss
 Piano in Mineralguss sp. 1,3 cm
 L 140+96 x P 20,8/51 cm

Structure and doors: 270 reflex perla melamine
 "Couture" outside washbasin in Mineralguss
 Top in Mineralguss 1.3 cm th.
 W 140+96 x D 20.8/51 cm



← Bianco e nero: la texture a righe bianche del frontale suggerisce un tocco di eleganza che si completa con il contrasto del colore nero delle maniglie.

Black and white: the texture of the front panel features white lines, giving this model its elegance, which is enhanced by the contrast with the black handles.



↑ La funzionalità e la praticità dei cassetti dotati di divisori permette di avere tutto in ordine. Dentro e fuori.

The functional and practical design of the drawers and their interior compartments makes it easy to keep everything tidy. Inside and out.





← Forme squadrate e ben definite per il lavabo, che è robusto e resistente.

The square-shaped basin, with its clean lines, is sturdy and tough.



BD020



↑ La capienza di questo lavabo è ideale per chi cerca le vasche grandi. Ampia e spaziosa ma perfettamente integrata nei mobili che la contengono.

The size of this basin is ideal for those who prefer a larger basin. While amply-dimensioned, it is the perfect match for the cabinets into which they are integrated.

L'armonia e la solidità di un piano e di un lavabo realizzati con lo stesso materiale: stratificato HPL in finitura Friuli.

The elegance and solidity of a top and a basin made using the same material: laminated HPL with a Friuli finish.

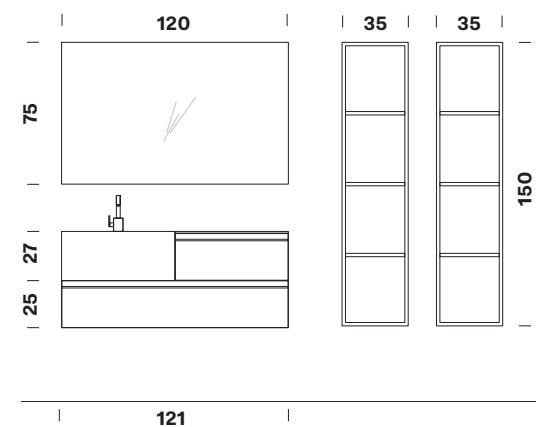

Scocca e frontali: 643 Beton nobilitato
Lavabo tuttofuori "Milos" in stratificato
HPL, finitura 3U Friuli
Piano in stratificato HPL sp. 1 cm,
finitura 3U Friuli
L 121+35+35 x P 46/20,8 cm

Structure and doors: 643 "Beton
melamine "Milos" outside washbasin
in HPL, "3U Friuli" finish
Top in HPL 1 cm th., "3U Friuli" finish
W 121+35+35 x D 46/20.8 cm



↓ Un'atmosfera sospesa avvolge l'ambiente;
il merito è della luce diffusa che proviene
dallo specchio retroilluminato.

A suspended atmosphere pervades the
room thanks to the diffused light coming
from the rear-lit mirror.



BD027



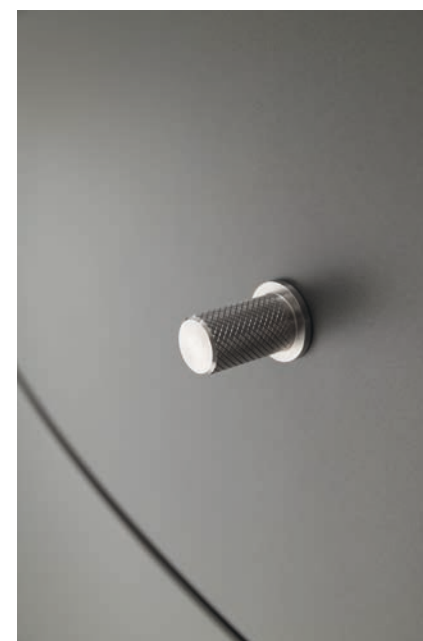

↑ Linee sinuose. La forma morbida del lavabo in Corian con vasca ovale rispetta perfettamente la sinuosità del mobile su cui si poggia.

Sinuous lines. The gentle form of the Corian oval-shaped basin is the perfect complement to the sinuous lines of the supporting cabinet.

← Semplice ma funzionale. Pur essendo piccolo come un cilindro, grazie alla superficie zigrinata il pomolo permette una facile apertura del cassetto.

Simple but highly functional. Though shaped like a small cylinder, the knurled surface of the knob makes for smooth and simple opening of the drawer.



← Colore, contrasto, colore. Il grigio scuro della finitura metallizzata richiama quello delle schiene degli elementi a giorno. Il bianco centrale delle strutture e delle pareti fa da contrasto.

Colour, contrast, and yet more colour. The dark grey of the metallic finish matches that of the rear panels of the open-fronted cabinets, while the white central section of the structure and the wall panels provide an eye-catching contrast.

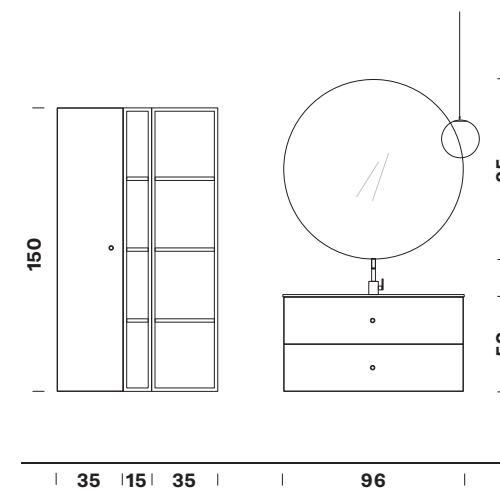

Scocca: 900 laccato opaco (M4 aluminum) e 110 bianco opaco nobilitato
 Frontali: 900 laccato opaco (M4 aluminum)
 Piano con vasca integrata "Bang" in Corian sp. 1,3 cm, vasca grande, finitura bianco
 L 85+96 x P 20,8/38/51 cm

Structure: 900 matt lacquered (M4 aluminum) and 110 matt white melamine
 Doors: 900 matt lacquered (M4 aluminum)
 "Bang" top with integrated basin in Corian 1.3 cm th., big basin, white finish
 W 85+96 x D 20.8/38/51 cm

Compab → B201

BD019



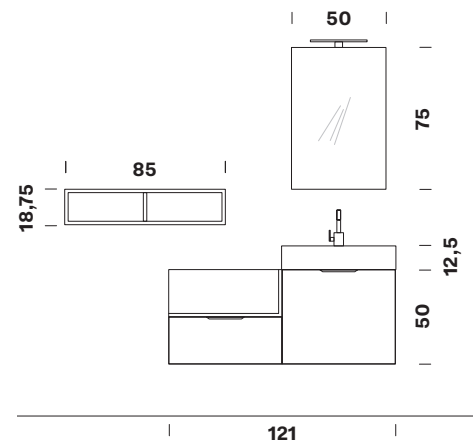

Scocca e frontali: 643 Beton nobilitato
 Lavabo consolle "Bali" in ceramica grigio opaco
 L 85+121 x P 15/46,5 cm

Structure and doors: 643 "Beton" melamine
 "Bali" console washbasin in matt grey ceramic
 W 85+121 x D 15/46.5 cm



← "Ton sur ton". Il grigio del lavabo in ceramica si accompagna perfettamente al grigio del mobile, che suggerisce l'effetto cemento.

"Ton sur ton". The grey colour of the ceramic basin is the perfect complement for that of the cabinet, which is reminiscent of a cement effect.



→ Una proposta bella e funzionale. Dietro le ante dello specchio si cela un contenitore per contenere gli oggetti quotidiani.

An attractive and functional idea. Behind the mirror doors, a cupboard for the everyday items.

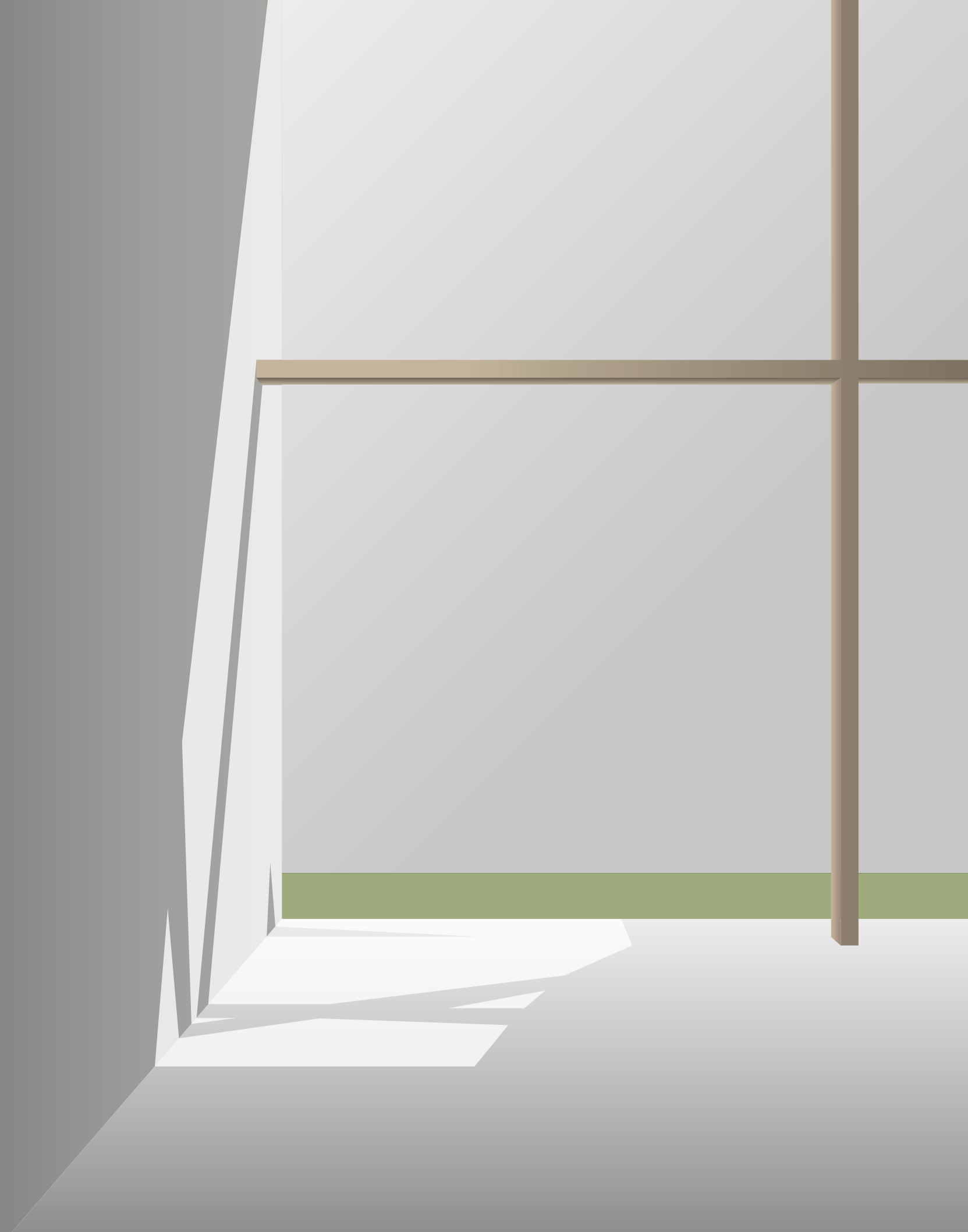

Forme d'arte e essenzialità.

Il design è una forma d'arte in evoluzione. Less is more* è la massima espressione del design moderno ed incarna la grande rivoluzione dell'essenzialità che entra nel quotidiano e diventa protagonista assoluta. Con il significato di "meno è più" ossia "meno è meglio", la frase sintetizza un minimalismo basato sulla ricerca della perfezione a cui si giunge imparando a sottrarre il superfluo.

Anche lo spazio vuoto ha una sua funzione e va rispettato.

Togliere il superfluo significa anche rispettare lo spazio vuoto e riconoscerne la presenza.

*** La frase è attribuita all'architetto tedesco Ludwig Mies van der Rohe, uno dei maestri del Movimento Moderno.**

Forms of art and simplicity.

Design as a form of art is in constant evolution. Less is more* is the utmost expression of modern design, and personifies the great revolution of simplicity which has influenced daily living, in which it plays a major rôle. The phrase itself – "less is more", meaning "less is better" – encapsulates a minimalism which centres on the search for perfection, which we can achieve by removing that which is superfluous.

Empty space, too, has a valid function which must be respected.

To remove that which is superfluous also signifies respecting empty spaces and recognizing their presence.

*** Phrase attributed to German architect Ludwig Mies van der Rohe, one of the pioneers of modernist architecture.**

BD008



B201 → BD008

Scocca: 211 Igloo nobilitato e 900 laccato opaco (M1 agave)
Frontali: 211 Igloo nobilitato
Lavabo consolle "Bliz" in Mineralguss bianco lucido L 105,5 cm
L 85+155,5 x P 15/51,5/20,8 cm

Structure: 211 "Igloo" melamine and 900 matt lacquered (M1 agave)
Doors: 211 "Igloo" melamine
"Bliz" console washbasin in glossy white Mineralguss W 105.5 cm
W 85+155.5 x D 15/51.5/20.8 cm

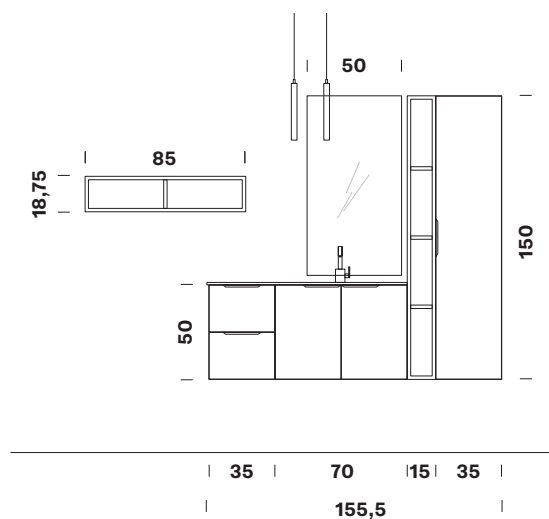

→ Il piacere del legno.
È marcata la venatura del legno nei frontali "igloo", abbinati a maniglie sporgenti in nichel spazzolato.

The sheer pleasure of wood. The pronounced grain of the wood used for the "igloo" front panels is the perfect match for the brushed nickel handles.





BD012



B201 → BD012



→ Un tocco di colore!
Fresco e vivace il mobile con trama
in legno e piano in vetro satinato.

A touch of colour!
The cabinet, with its wooden frame
and satin-finish glass top is new
and eye-catching.

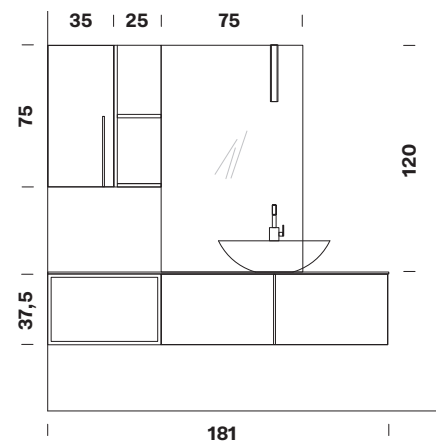

Scocca e frontali: 290 Cross laccato opaco (M1 agave)
Lavabo tuttofuori "Softly" in ceramica
Piano in cristallo satinato sp. 1 cm, finitura M1 agave
L 181 x P 46/20,8 cm

Structure and doors: 290 Cross matt lacquered (M1
agave)
"Softly" outside washbasin in ceramic
Crystal top 1 cm th., M1 agave finish
W 181 x D 46/20.8 cm





BD009

Scocca e frontali: 262 Ghadira nobilitato e 900 laccato opaco (M2 cactus)
 Lavabo tuttofuori "Bali" in ceramica grigio opaco
 Piano in stratificato HPL (3U Friuli) sp. 1 cm
 L 51+141 x P 38/51 cm

Structure and doors: 262 "Ghadira" melamine and 900 matt lacquered (M2 cactus)
 "Bali" outside washbasin in matt grey ceramic
 Top in HPL (3U Friuli) 1 cm th.
 W 51+141 x D 38/51 cm

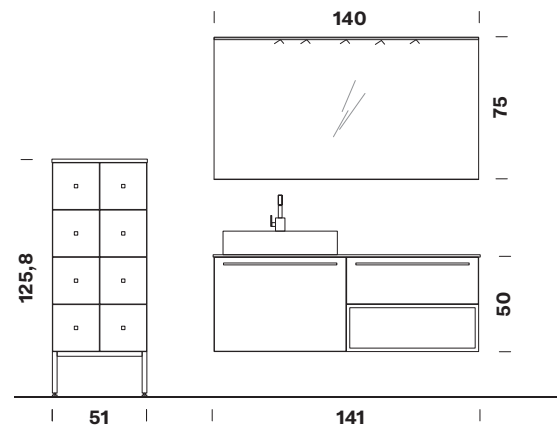

→ Wap è una specchiera importante e al contempo funzionale, grazie all'applicazione della mensola che consente l'appoggio di piccoli oggetti.

Wap is an eye-catching yet highly functional mirror, thanks to the application of a shelf on which to place smaller items.





↑ Spazio e ordine. Il cassetto dotato di divisori interni permette di tenere in ordine anche gli oggetti di uso quotidiano.

Space and order. The drawer is fitted with internal compartments in which to place frequently-used items.

Compab → B201

BD011



↓ Forme squadrate e ben definite per il lavabo appoggiato su un piano in simil pietra, robusto e resistente.

Clearly-defined square forms for the basin, which is supported by a tough and long-lasting top in imitation stoneware.

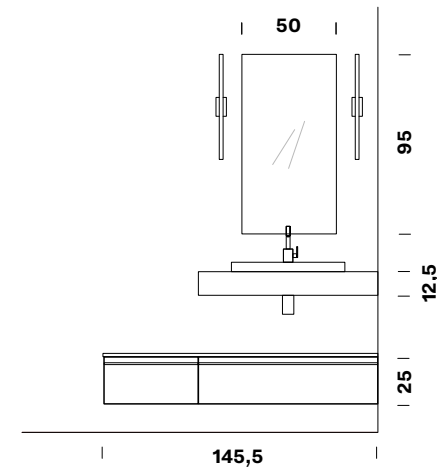

Scocca e frontali:
900 laccato opaco (H9 lichene)
Lavabo incasso soprapiano "Paola"
in Mineralguss bianco opaco
Piano legno sp. 12,5 cm, finitura "148 Carnik"
L 145,5 x P 51 cm

Structure and doors:
900 matt lacquered (H9 lichene)
"Paola" over-counter washbasin in matt
white Mineralguss
Wood top 12.5 cm th., "148 Carnik" finish
W 145.5 x D 51 cm





Caratteristiche tecniche della collezione

Technical features
of the collection



Scocca in truciolare CARB P2

finiture disponibili:

- 110 Bianco opaco
- 111 Bianco lucido
- 210 Seta
- 211 Igloo
- 216 Eastwood
- 218 Vic
- 222 Gif
- 261 Expanse
- 262 Ghadira
- 263 Reno
- 265 Tivoli
- 268 Cross
- 270 Reflex perla
- 271 Reflex carbon
- 272 Pecan
- 273 Hiro
- 274 Laos
- 275 Evoke
- 276 Kiki
- 290 Cross laccato colore opaco
- 291 Reflex laccato colore opaco
- 292 Laos laccato colore opaco
- 643 Beton
- 649 Glauco
- 900 laccato colore opaco

- 901 laccato colore lucido
- 940 laccato colore sabbiato

Frontali nobilitati in truciolare CARB P2

finiture disponibili:

- 110 Bianco opaco
- 210 Seta
- 211 Igloo
- 216 Eastwood
- 218 Vic
- 222 Gif
- 261 Expanse
- 262 Ghadira
- 263 Reno
- 265 Tivoli
- 268 Cross
- 270 Reflex perla
- 271 Reflex carbon
- 272 Pecan
- 273 Hiro
- 274 Laos
- 275 Evoke
- 276 Kiki
- 290 Cross laccato colore opaco
- 291 Reflex laccato colore opaco
- 292 Laos laccato colore opaco

- 643 Beton
- 649 Glauco

Frontali laccati in MDF laccato

finiture disponibili:

- 111 Bianco lucido
- 900 laccato colore opaco
- 901 laccato colore lucido
- 940 laccato colore sabbiato

Maniglia di serie

- cod. 151 cromo

Altre maniglie**o pomoli disponibili**

- cod. 149–152 bianco
- cod. 161 cromo
- cod. 166 bianco
- cod. 680–681–682 acciaio zigrinato
- cod. 690 nero
- cod. 691 nichel spazzolato
- cod. 692 oro spazzolato
- cod. 356 nichel spazzolato
- cod. 357 acciaio zigrinato
- Push&Pull system

Body in CARB P2 chipboard

finishes available:

- 110 Matt white
- 111 Glossy white
- 210 Seta
- 211 Igloo
- 216 Eastwood
- 218 Vic
- 222 Gif
- 261 Expanse
- 262 Ghadira
- 263 Reno
- 265 Tivoli
- 268 Cross
- 270 Reflex perla
- 271 Reflex carbon
- 272 Pecan
- 273 Hiro
- 274 Laos
- 275 Evoke
- 276 Kiki
- 290 Cross color matt lacquered
- 291 Reflex color matt lacquered
- 292 Laos color matt lacquered
- 643 Beton
- 649 Glauco
- 900 Color matt lacquered

- 901 Color gloss lacquered
- 940 Color embossed lacquered

Melamine doors in CARB P2 chipboard

finishes available:

- 110 Matt white
- 210 Seta
- 211 Igloo
- 216 Eastwood
- 218 Vic
- 222 Gif
- 261 Expanse
- 262 Ghadira
- 263 Reno
- 265 Tivoli
- 268 Cross
- 270 Reflex perla
- 271 Reflex carbon
- 272 Pecan
- 273 Hiro
- 274 Laos
- 275 Evoke
- 276 Kiki
- 290 Cross color matt lacquered
- 291 Reflex color matt lacquered
- 292 Laos color matt lacquered

- 643 Beton
- 649 Glauco

Lacquered doors in MDF chipboard

finishes available:

- 111 Glossy white
- 900 Color matt lacquered
- 901 Color gloss lacquered
- 940 Color embossed lacquered

Standard handle

- cod. 151 chromed

Other handles or knobs available

- cod. 149–152 white
- cod. 161 chromed
- cod. 166 white
- cod. 680–681–682 knurled steel
- cod. 690 black
- cod. 691 brushed nickel
- cod. 692 brushed gold
- cod. 356 brushed nickel
- cod. 357 knurled steel
- Push&Pull system

Maniglie

Handles

Una caratteristica molto importante della collezione B201 è l'anta liscia nelle sue varie finiture la quale può essere impreziosita dalla maniglia a scelta. Può essere un semplice pomolo squadrato o a cilindro zigrinato, una semplice maniglia dritta oppure sono disponibili maniglie che rispettano la larghezza dell'anta in modo da avere un continuo visivo. Altra possibilità ancora è di non applicare nessuna maniglia e di aprire l'anta o cassetto con il sistema Push&Pull.

One of the most important features of the B201 collection is the plain door, which is available in a range of finishes and can be enhanced by a choice of handles; these may be in the form of a simple square knob or a knurled cylinder, or a simple linear handle or even a handle of the same width of the door, which provides a sort of visual continuity.

Another idea is not to fit a handle at all, and open the door or drawer using the Push&Pull system.

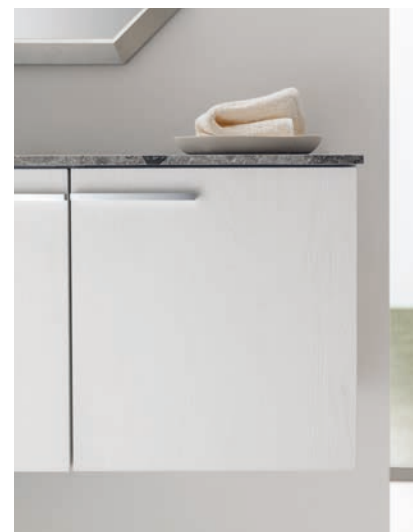

Finiture Finishes

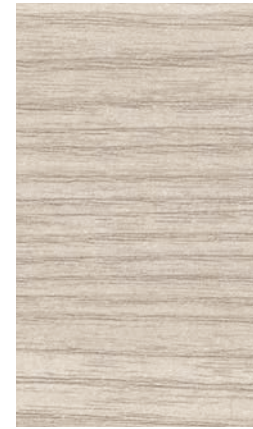

↑
263 Reno



↑
265 Tivoli



↑
268 Cross



↑
270 Reflex perla

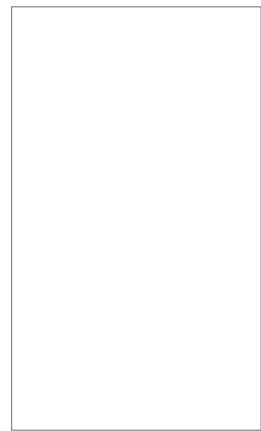

↑
110/111 Bianco opaco-lucido



↑
210 Seta

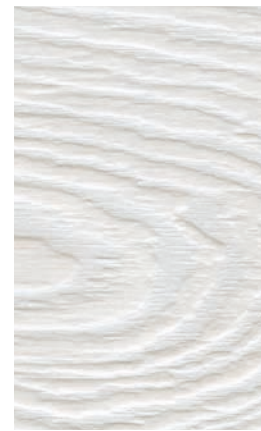

↑
211 Igloo



↑
216 Eastwood



↑
271 Reflex carbon



↑
272 Pecan



↑
273 Hiro



↑
274 Laos



↑
218 Vic



↑
222 Gif



↑
261 Expanse



↑
262 Ghadira



↑
275 Evoke



↑
276 Kiki



↑
643 Beton



↑
649 Glauco



B201 → BD001 | p. 18



B201 → BD002 | p. 6



B201 → BD008 | p. 160



B201 → BD009 | p. 171



B201 → BD003 | p. 128



B201 → BD004 | p. 134



B201 → BD010 | p. 90



B201 → BD011 | p. 176



B201 → BD012 | p. 165



B201 → BD005 | p. 75



B201 → BD006 | p. 25



B201 → BD007 | p. 116



B201 → BD013 | p. 56



B201 → BD014 | p. 68



B201 → BD015 | p. 47



B201 → BD016 | p. 62



B201 → BD017 | p. 53



B201 → BD023 | p. 109



B201 → BD024 | p. 102



B201 → BD025 | p. 38



B201 → BD018 | p. 33



B201 → BD019 | p. 154



B201 → BD020 | p. 143



B201 → BD026 | p. 85



B201 → BD027 | p. 148



B201 → BD021 | p. 80



B201 → BD022 | p. 97



B201 → BD028 | p. 13



B201 → BD029 | p. 123



Compab srl
Viale Lino Zanussi, 9
33070 Maron di Brugnera
Pordenone - Italy
Tel. +39 0434 624920
Fax +39 0434 624679
info@compabilbagno.it

www.compab.it

Una stanza immaginaria che si trova in una posizione indefinita tra il cielo e la terra, si dice sia il modo originario per rappresentare il concetto di *ma*.

An imagined room positioned uncertainly between heaven and earth is said to be the original way of picturing the concept of *ma*.

