

TABULA





# TABULA

Un viaggio nel minimalismo tra Oriente e Occidente  
*A journey into minimalism between East and West*

Due anime caratterizzano il design minimalista delle collezioni Tabula: l'incontro tra il design scandinavo e il minimalismo giapponese. Due culture lontane ma legate da un peculiare e affascinante rapporto tra l'essere umano e l'ambiente che lo circonda, a cui abbiamo voluto rendere tributo con le nostre composizioni.

Se in entrambe le filosofie di progettazione è dominante la vocazione alla funzionalità e al minimalismo, sia nella cultura nordica che in quella nipponica vi sono dei concetti peculiari che riflettono l'approccio di questi popoli alla vita quotidiana, alla bellezza e, non ultimo, al design. Ne abbiamo scelti quattro, due dal mondo scandinavo e due dalla tradizione giapponese, e abbiamo voluto abbinare a ciascuno di essi una parola intraducibile che meglio ne potesse esprimere l'essenza.

La semplicità / Shibui  
L'equilibrio / Lagom  
La luce / Komorebi  
La natura / Friluftsliv

Da questa ricerca di significato e di senso è nata la nostra ispirazione. Da questo è nata Tabula.

*Two styles are the distinctive features of the minimalist design of the Tabula collections: the encounter between Scandinavian design and Japanese minimalism. Two cultures that are distant yet linked by a unique and fascinating relationship between people and the environment that surrounds them. With our arrangements we wanted to pay tribute to them.*

*While the focus on functionality and minimalism is predominant in both design philosophies, distinctive concepts in Nordic and in Japanese cultures reflect these peoples' approach to everyday life, beauty and, not least, design. We chose four, two from the Scandinavian world and two from the Japanese tradition, and decided to match each one with an untranslatable word that would best express its essence.*

*Simplicity / Shibui  
Balance / Lagom  
Light / Komorebi  
Nature / Friluftsliv*

*This search for meaning and sense gave rise to our inspiration. The outcome is Tabula.*



L'essenza della forma si svela in una geometria armoniosa. Una rinuncia al superfluo che si riempie di significato: dalla sottrazione nasce la poesia di abitare lo spazio. Tra pieni e vuoti, tra luce e ombra, emerge un incontro di linee che dà vita ad un ambiente dal ricercato equilibrio.

*The essence of shape is revealed in harmonious design. Renouncing the superfluous becomes meaningful: exclusion leads to the poetic nature of experiencing space. Among open and closed spaces, light and shadow, a meeting of lines emerges that gives rise to a context featuring a refined balance.*







# TABULA



## COMPAB

La cornice in rilievo che caratterizza il profilo dell'anta è l'elemento distintivo della collezione Tabula. Un gioco di volumi che crea dinamismo senza rinunciare al carattere essenziale delle serie.

*The relief frame that defines the door profile is the distinctive element of the Tabula collection. An interplay of volumes creates dynamic appeal without sacrificing the essential character of the range.*





Il legno incontra le ricercate superfici materiche per un contrasto accattivante di colore e sensazioni tattili. La scelta dei materiali richiama l'elemento naturale per uno stile minimalista ma accogliente.

*Wood comes together with refined textured surfaces for an appealing colour contrast and tactile sensations. The choice of materials recalls the natural element for a minimalist yet cosy style.*





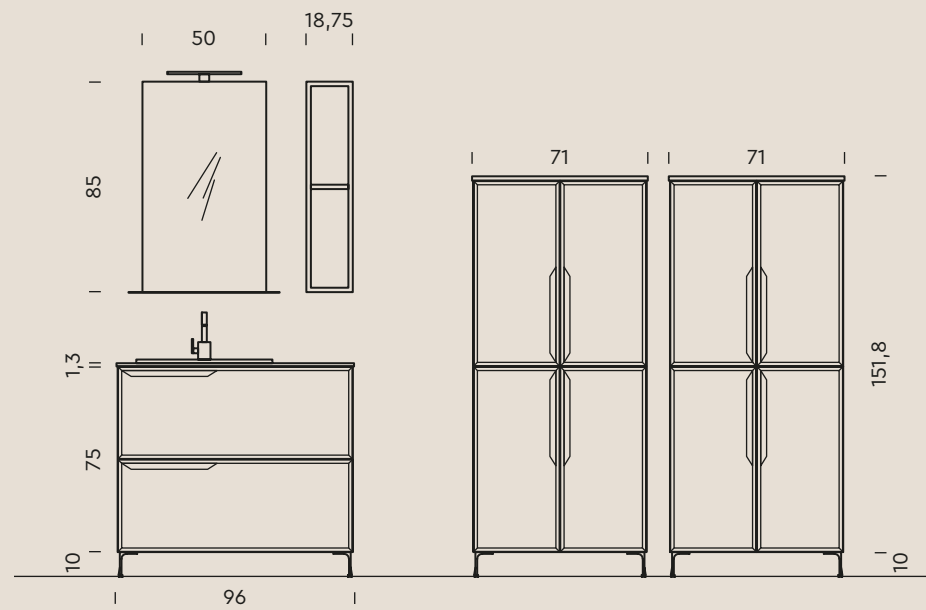

## COMP. TB01

Scocca e frontali: 837 rovere mais.  
 Lavabo incasso soprapiano "S20" in ceramica bianco lucido.  
 Piano in quarzo-resina sp. 1,3 cm, finitura 9C Terrazzo black.  
 L 96+71+71 x P 51/38 cm

*Structure and doors: 837 "mais" oak.  
 "S20" over-counter washbasin in gloss white ceramic.  
 Top in quartz-resin 1.3 cm th., "9C Terrazzo black" finish.  
 W 96+71+71 x D 51/38 cm*





## > Semplicità / Simplicity

### **Shibui**

agg. [shibui] Giapponese / adj. [shibui] Japanese

*Bellezza semplice, delicata e discreta.  
/ Simple, subtle and understated beauty.*

Un termine chiave del minimalismo giapponese è shibui, un concetto intrinseco al concetto di bellezza. La bellezza shibui è semplice, impercettibile e discreta. Shibui è lo scopo ultimo del design. Una vocazione all'essenziale che però è semplicità solo in apparenza. Osservandola in modo più profondo, infatti, si scopre l'intreccio della trama. Si svela la ricchezza di dettagli. Un equilibrio tra semplicità e complessità che permette sempre di trovare nel design nuovi significati.

*A central word in Japanese minimalism is 'shibui', a concept intrinsic to the concept of beauty. Shibui beauty is simple, imperceptible and subtle. Shibui is the ultimate goal of design. A quest for the essential that is, however, simplicity only in appearance. When taking a closer look, the intricacy of the pattern can be discovered. The wealth of detail is revealed. A balance of simplicity and complexity, which always allows new meanings to be found in design.*

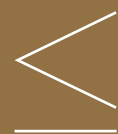



TABULA

COMPAB



TABULA #02

2023





Un dettaglio essenziale ma pieno di carattere per i mobili contenitori. La maniglia in alluminio nero opaco crea un ricercato contrasto con la superficie in legno. Per ambienti bagno dallo stile contemporaneo.

*Storage units feature essential detail yet great character. The matt black aluminium handle creates a refined contrast with the wooden surface. For bathroom settings with a contemporary style.*









COMPAB

TABULA

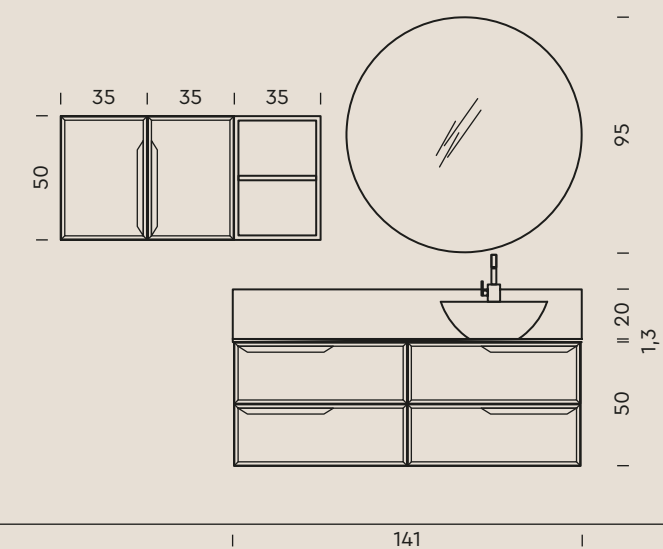
**COMP. TB02**

Scocca e frontali: 837 rovere mais.

Lavabo in appoggio "Roma" in ceramica bianco opaco.

Piano e alzata posteriore in gres sp. 1,3 cm, finitura 29 Ardesia bianco.

L 70+141 x P 20,8/51 cm

*Structure and doors: 837 "mais" oak.*

*"Roma" countertop washbasin in matt white ceramic.*

*Top and back upstand in stoneware 1.3 cm th., "29 Ardesia bianco" finish.*

*W 70+141 x D 20.8/51 cm*

TABULA #02

2023



TABULA

2023

COMPAB

TABULA #03







Semplicità ispirata al minimalismo giapponese per il profilo nero e la superficie materica del lavabo. Si armonizzano con il vano contenitore in legno che richiama il design scandinavo.

*Simplicity inspired by Japanese minimalism with a black profile and washbasin with a textured surface. They are in harmony with the wooden storage compartment reminiscent of Scandinavian design.*







Un delicato equilibrio tra chiaroscuri.  
Per un ambiente che trasmette una  
sensazione di calma e tranquillità.

*A delicate balance of chiaroscuro  
effects. For a space that conveys  
a sensation of calm and serenity.*



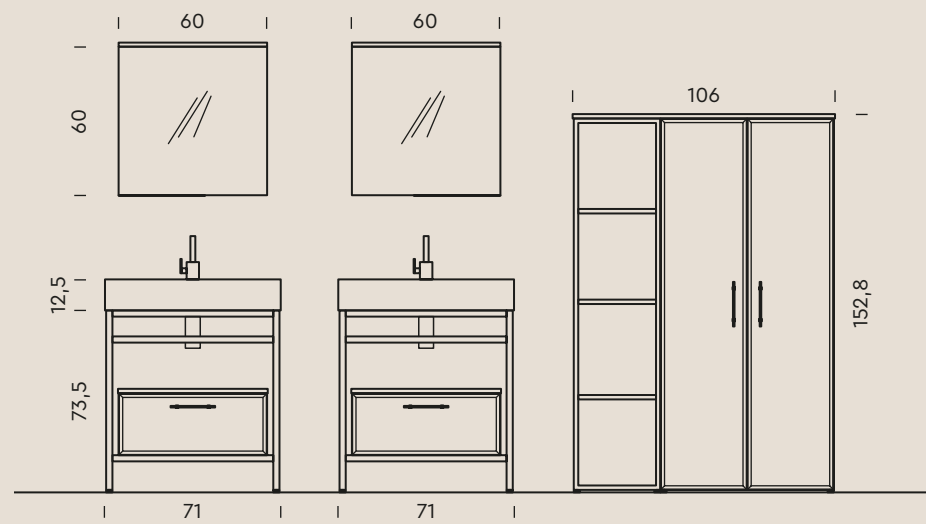

**COMP. TB03**

Scocca e frontali: 837 rovere mais.

Piano con vasca integrata "ES 50" in gres sp. 12,5 cm, vasca piccola, finitura 28 Ardesia nero.

L 71+71+106 x P 51/38 cm

Structure and doors: 837 "mais" oak.

"ES 50" top with integrated basin in stoneware 12.5 cm th., small basin, "28 Ardesia nero" finish.

W 71+71+106 x D 51/38 cm





Riportare l'elemento naturale nello spazio domestico per riconnettersi con una dimensione più autentica. In equilibrio con l'ambiente che ci circonda. Ricercare la nostra vera essenza per trovare la calma dell'anima. Liberare gli spazi, celebrare i vuoti, per far entrare la luce.

*Bringing the natural element back into the home space to reconnect with a more authentic dimension. In harmony with our surroundings. Seeking our true essence to find inner calm. Freeing up spaces, cherishing open areas to let light in.*







## TABULA



## COMPAB

Design essenziale con un focus sulla funzionalità.  
La collezione Tabula offre ampie soluzioni contenitive per ottimizzare lo spazio a disposizione senza rinunciare ad un'estetica minimale.

*Essential design with a focus on functionality.  
The Tabula collection offers plenty of storage solutions to optimise available space without forgoing minimalist aesthetic appeal.*



TABULA

COMPAB



TABULA #04

2023





COMPAB

TABULA

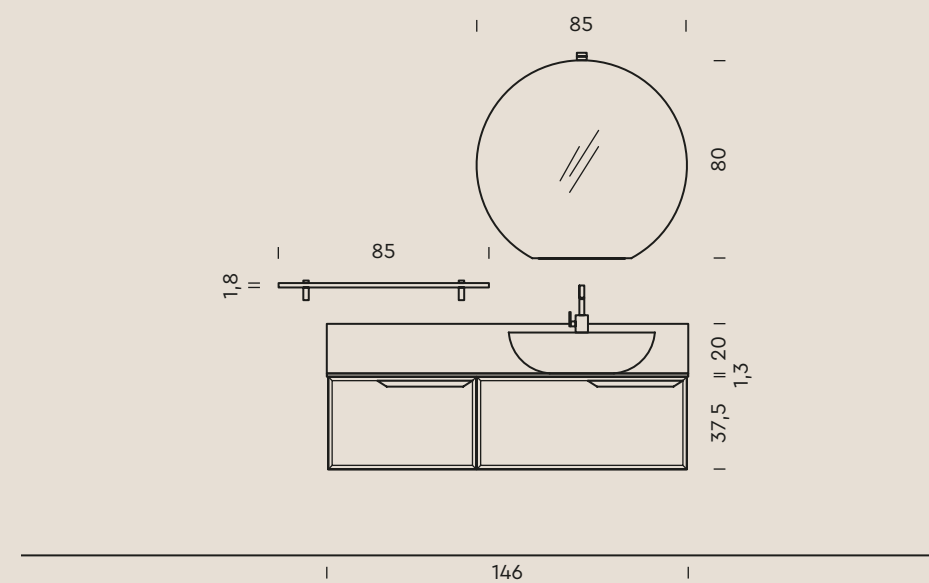

## COMP. TB04

Scocca e frontali: 837 rovere mais.  
 Lavabo in appoggio "Bologna-N" in ceramica nero opaco.  
 Piano in quarzo-resina sp. 1,3 cm, finitura 9A Terrazzo grey.  
 L 146+85 x P 51/16 cm

*Structure and doors: 837 "mais" oak.  
 "Bologna-N" countertop washbasin in matt black ceramic.  
 Top in quartz-resin 1.3 cm th., "9A Terrazzo grey" finish.  
 W 146+85 x D 51/16 cm*

TABULA #04

2023



## > Equilibrio / Balance

### Lagom

avv. [la-gom] Svedese / adv. [la-gom] Swedish

*Non troppo. Non troppo poco. Il giusto.  
/ Not too much. Not too little. Just right.*

Lagom è la ricerca del giusto equilibrio. È il desiderio di vivere una vita a passo moderato attraverso una resistenza gentile al caos e al consumismo. Nella cultura nordica il minimalismo agisce per sottrazione ma senza essere austera privazione. È una ricerca della felicità attraverso la rinuncia all'eccesso, per dare risalto a ciò che è davvero essenziale. Questo vale anche per il design e gli ambienti in cui si vive: armonia ed equilibrio li rendono funzionali e sostenibili senza rinunciare ad essere caldi e accoglienti.

*Lagom is the search for the right balance. It is the desire to live a life at a leisurely pace by gently resisting chaos and consumerism. In Nordic culture, minimalism means removing but without austere deprivation. It is a quest for happiness by forgoing excess in order to highlight what is truly essential. This also applies to design and living spaces: harmony and balance make them functional and sustainable without sacrificing warmth and cosiness.*

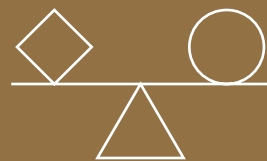









COMPAB

TABULA



Il design minimalista della collezione Tabula permette ampie possibilità di personalizzazione dell'ambiente. Ad esempio nella scelta dei rivestimenti o degli accessori.

*The minimalist design of the Tabula collection provides much scope for customised options in this context. For example, in the choice of coverings or accessories.*

TABULA #05

2023



TABULA

COMPAB



TABULA #05

2023

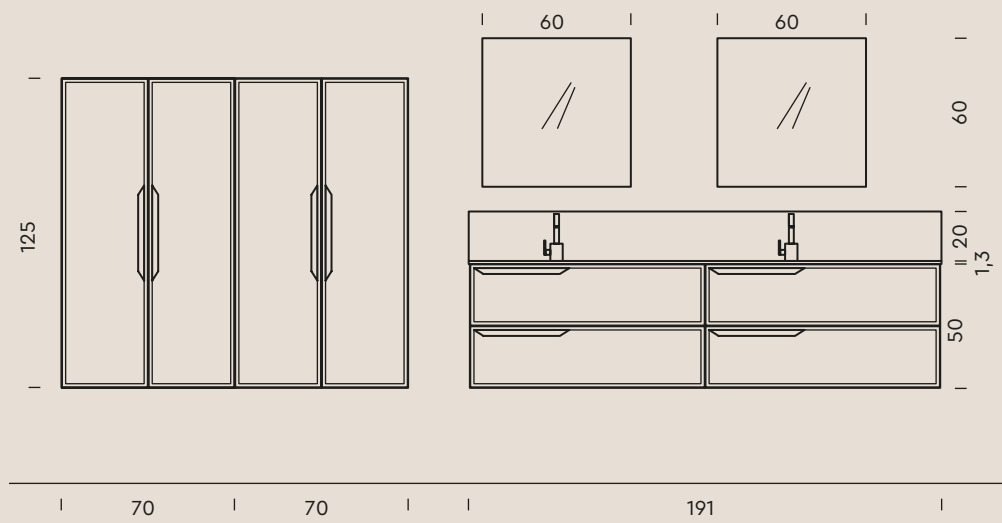

**COMP. TB05**

Scocca e frontali: 837 rovere mais.

Piano con vasca integrata "Itaca 50" in Tekor sp. 1,3 cm, vasca doppia.  
L 140+191 x P 20,8/51 cm

*Structure and doors: 837 "mais" oak.*

*"Itaca 50" top with integrated basin in Tekor 1.3 cm th., double basin.  
W 140+191 x D 20.8/51 cm*





TABULA

COMPAB



TABULA #06

2023





Eleganza e funzionalità. La mensola in alluminio con ripiano in vetro crea un raffinato elemento di accento nell'ambiente bagno, coordinandosi allo stile del mobile lavabo e degli accessori.

*Elegance and functionality. The aluminium shelf with glass top creates a refined accent piece in the bathroom, coordinating with the style of the washbasin unit and accessories.*







COMPAB

TABULA

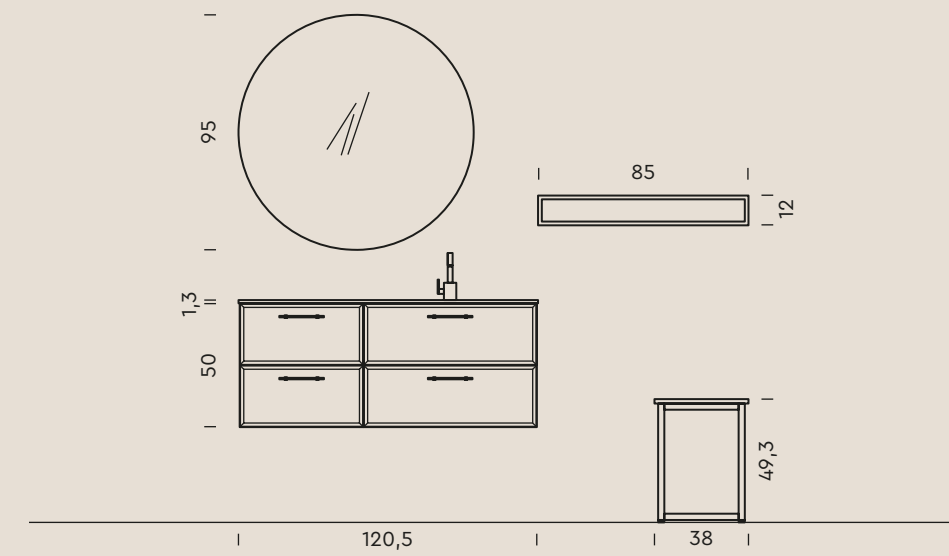
**COMP. TB06**

Scocca e frontali: 837 rovere mais.

Lavabo consolle "Ibiza" in Minera-Kolor (H5 datura) L 120,5 cm.

L 120,5+85+38 x P 51,5/12/38 cm

Structure and doors: 837 "mais" oak.

"Ibiza" console washbasin in Minera-Kolor (H5 datura) W 120.5 cm.

W 120.5+85+38 x D 51.5/12/38 cm

TABULA #06

2023



## > Luce / Light

### **Komorebi**

n. [kòmórébí] Giapponese / n. [kòmórébí] Japanese

*La luce che filtra tra le foglie degli alberi.  
/ Light filtering through the leaves of a tree.*

Luce e ombra sembrano diventare palpabili nell'immagine potente ed evocativa dei raggi del sole che attraversano le chiome degli alberi. Nella cultura nipponica questo fenomeno viene raccontato attraverso la parola komorebi e riflette un aspetto peculiare della sensibilità e dell'estetica giapponese. La bellezza non risiede nell'oggetto in sé ma nell'equilibrio che viene a crearsi tra luce e oscurità. Il fascino dell'ombra si riflette anche nella casa giapponese tradizionale che è caratterizzata da un delicato equilibrio tra luci e ombre.

*Light and shadow appear to become tangible in the powerful and evocative image of sunlight passing through treetops. In Japanese culture, this phenomenon is described by the word 'komorebi' and reflects a unique aspect of Japanese sensitivity and aesthetic appeal. Beauty does not lie in an object itself but in the balance created between light and darkness. This fascination with shadow is also reflected in the traditional Japanese home, which features a delicate balance of light and shadow.*





Leggerezza e profondità.  
Pieno e vuoto. Luce e oscurità.  
Non una collezione di oggetti  
ma un'anima in ogni oggetto.  
Nell'equilibrio degli opposti si svela  
la complessità. Emerge una bellezza  
raffinata e autentica. Ambienti pratici  
e funzionali ma resi preziosi da un  
design unico e riconoscibile.

*Lightness and depth. Open and  
closed spaces. Light and darkness.  
Not a collection of objects but an  
essence in every object.  
Complexity is revealed in the  
balance of opposites. A refined  
and authentic beauty emerges.  
Contexts that are practical and  
functional yet made precious by  
a unique and recognisable design.*







COMPAB

TABULA



Libertà di abbinamento. Il design della collezione Tabula può essere coordinato a diverse scelte di stile e di materiali.  
Come la finitura ad effetto corten presentata in questa proposta.

*A choice of combinations. The design of the Tabula collection can be coordinated according to the choice of different styles and materials.  
For example, the corten-effect finish presented in this arrangement.*

TABULA #07

2023







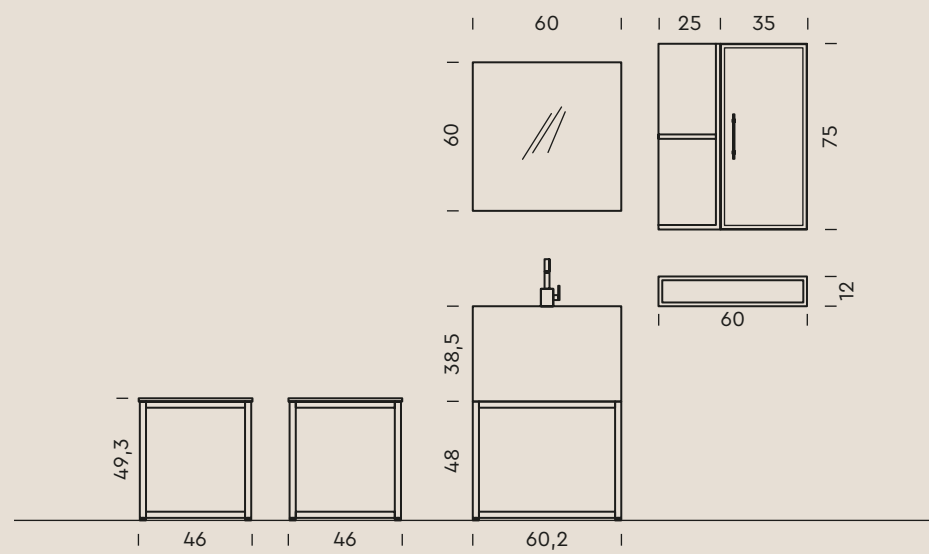

## COMP. TB07

Scocca e frontali: 837 rovere mais.  
Lavabo in appoggio "Atene" in gres, finitura 2K Korten.  
L 46+46+60,2+60 x P 46/20,8 cm

Structure and doors: 837 "mais" oak.  
"Atene" countertop washbasin in stoneware, "2K Korten" finish.  
W 46+46+60.2+60 x D 46/20.8 cm











All'esterno, linee essenziali e design minimale. All'interno, una capacità contenitiva ampia e funzionale.

*On the outside, essential lines and minimalist design. On the inside, generous and functional storage space.*





COMPAB

TABULA

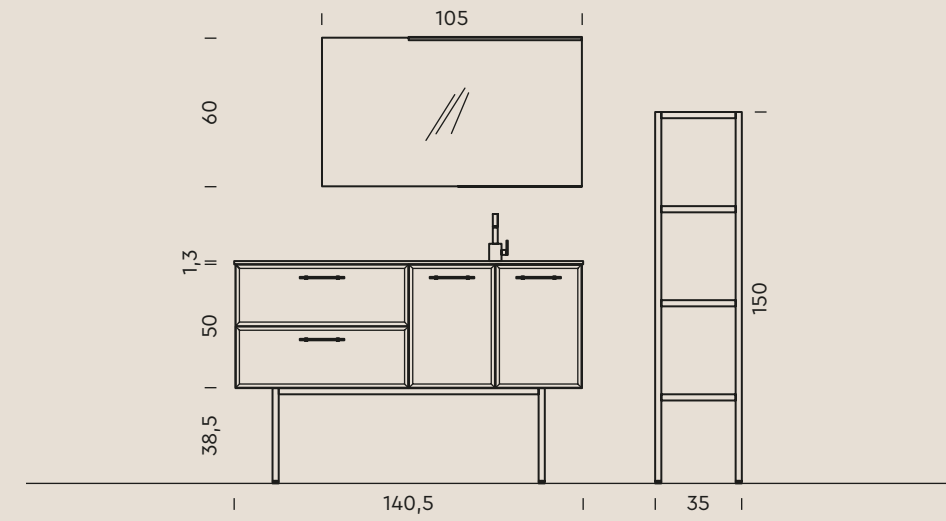
**COMP. TB08**

Scocca e frontali: 837 rovere mais.

Lavabo consolle "Bliz" in Mineralguss bianco lucido L 140,5 cm.  
L 140,5+35 x P 51,5/37 cm

Structure and doors: 837 "mais" oak.

"Bliz" console washbasin in gloss white Mineralguss W 140.5 cm.  
W 140.5+35 x D 51.5/37 cm

TABULA #08

2023



Progettare con il fine ultimo della semplicità per spazi che donano a chi li abita tranquillità ed equilibrio.

*Designing with the ultimate goal of simplicity to create spaces that bring calmness and balance to those who use them.*







COMPAB

TABULA



Contemporaneo e funzionale lo scaffale con profili neri e mensole in vetro. L'ariosa leggerezza di un sistema a giorno per arredare senza appesantire lo spazio.

*A contemporary and functional shelving system with black profiles and glass shelves. The airy lightness of an open system for furnishing without cluttering the space.*

TABULA #08

2023



TABULA

COMPAB



TABULA #09

2023





Il legno è vivo e organico. La collezione Tabula ha come filo conduttore l'elemento naturale in contrasto con la profondità del colore nero per creare ambienti calmi e rilassanti.

*Wood is alive and organic. The common theme of the Tabula collection involves a natural element contrasting with the depth of the colour black to create calm and relaxing interiors.*







COMPAB

TABULA

La collezione Tabula nasce con la proposta base della maniglia in ghisa nero opaco. Un profilo leggero e accattivante che garantisce una presa facile ed ergonomica.

*The Tabula collection comes with a standard matt black cast iron handle. A light and attractive profile ensures an easy and ergonomic grip.*



TABULA #09

2023



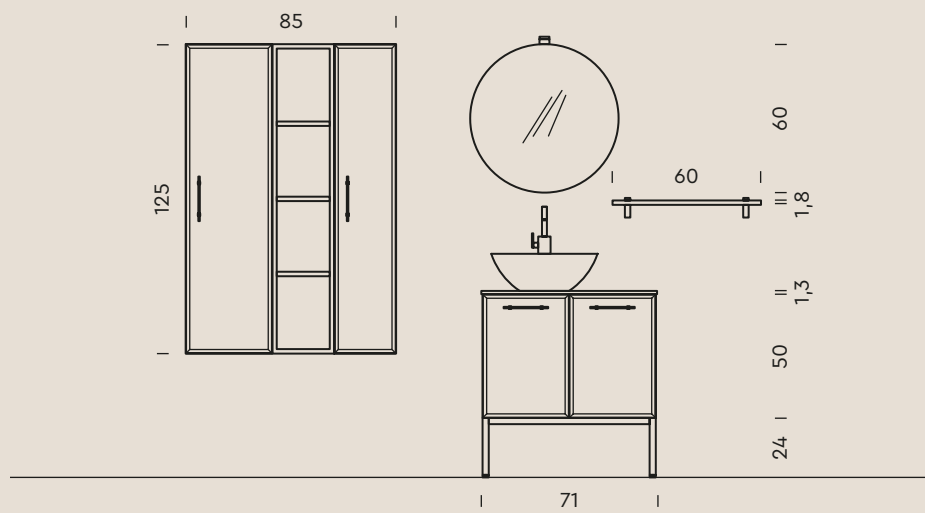

## COMP. TB09

Scocca e frontali: 837 rovere mais.

Lavabo in appoggio "Firenze" in ceramica nero opaco.

Piano in quarzo-resina sp. 1,3 cm, finitura 9C Terrazzo black.

L 85+71+60 x P 37/51/16 cm

Structure and doors: 837 "mais" oak.

"Firenze" countertop washbasin in matt black ceramic.

Top in quartz-resin 1.3 cm th., "9C Terrazzo black" finish.

W 85+71+60 x D 37/51/16 cm





## > Natura / Nature

### Friluftsliv

n. [free-lofts-live] Norvegese / n. [free-lofts-live] Norwegian

*La vita all'aria aperta.  
/ Outdoor life.*

Nei popoli nordici il legame con l'esperienza naturale ha un significato culturale profondo, quasi sacro. L'amore per la vita all'aria aperta è riassunto nella parola norvegese Friluftsliv. Nonostante i ritmi rapidi della vita contemporanea, è fondamentale per il popolo norvegese ritagliarsi del tempo da trascorrere a contatto con la natura. Questa necessità di connessione con la natura si riflette anche nell'ambiente domestico ed è di ispirazione per il design che predilige l'utilizzo di materiali naturali, tinte morbide e atmosfere accoglienti.

*For Nordic peoples, the bond with experiences of nature has a deep, almost sacred cultural significance. Their love of outdoor life is summed up in the Norwegian word 'Friluftsliv'. Despite the fast pace of contemporary life, it is essential for Norwegians to make time for contact with nature. This need to connect with nature is also reflected in the home environment and is an inspiration for design that prioritises the use of natural materials, soft shades and cosy atmospheres.*





TABULA

COMPAB



TABULA #10

2023





TABULA



COMPAB

A partire dalla scelta delle superfici in legno, nella collezione Tabula la natura invade l'ambiente domestico. Il design crea spazi armonici e ariosi, che si lasciano attraversare dalla luce.

*Starting with the choice of wooden surfaces, nature invades the home environment with the Tabula collection. The design creates harmonious, airy spaces that let light shine through.*



TABULA

COMPAB







## TABULA

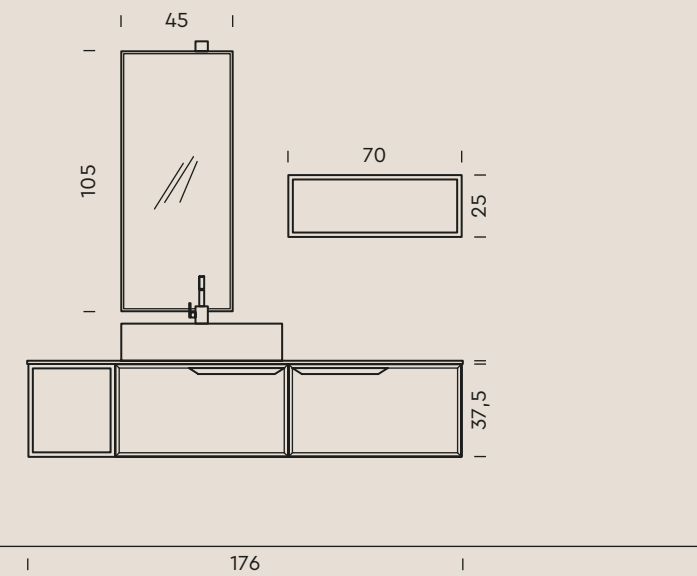

## COMP. TB10

Scocca e frontali: 837 rovere mais.  
 Lavabo in appoggio "Logyn" in gres, finitura 2K Korten.  
 Piano in gres sp. 1,3 cm, finitura 2K Korten.  
 L 176 x P 51 cm

Structure and doors: 837 "mais" oak.  
 "Logyn" countertop washbasin in stoneware, "2K Korten" finish.  
 Top in stoneware 1.3 cm th., "2K Korten" finish.  
 W 176 x D 51 cm

COMPAB

TABULA #10

2023



TABULA

COMPAB



2023

TABULA #11





L'abbinamento tra l'essenza in legno e colori tenui mette in risalto l'estrema pulizia della forma della collezione Tabula. Per ambienti bagno di design dall'atmosfera rilassante e accogliente.

*The combination of wood and soft colours emphasises the extremely clear-cut shapes of the Tabula collection. For designer bathrooms with a relaxing and cosy atmosphere.*





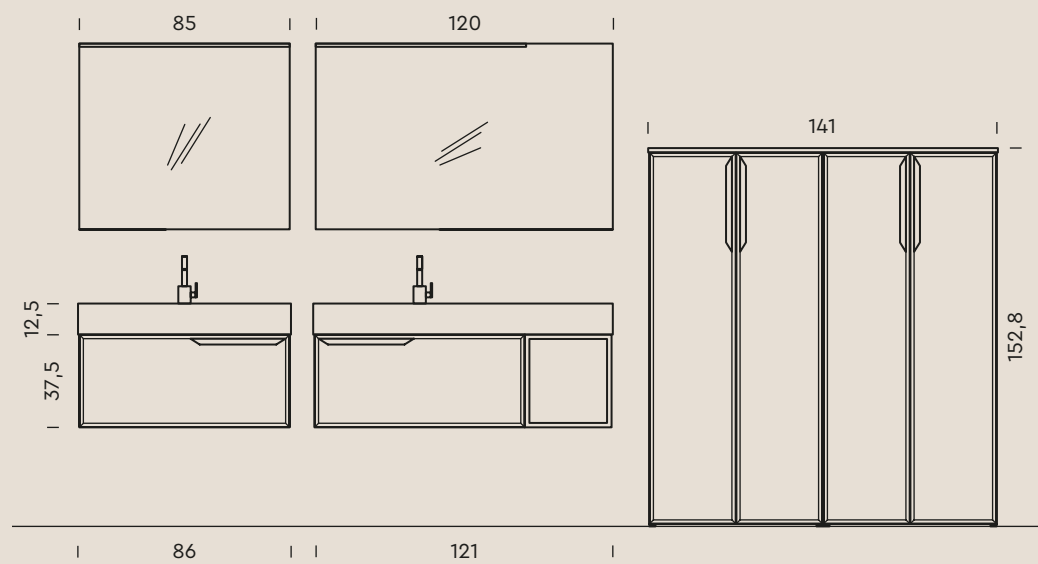

## COMP. TB11

Scocca e frontali: 837 rovere mais.

Piani con vasca integrata "Samo 50" in Tekor sp. 12,5 cm, vasca piccola.  
L 86+121+141 x P 51/38 cm

Structure and doors: 837 "mais" oak.

"Samo 50" tops with integrated basin in Tekor 12.5 cm th., small basin.  
W 86+121+141 x D 51/38 cm







COMPAB

TABULA

Un dialogo costante tra l'interno e l'esterno.  
Forme in sintonia con l'ambiente naturale che  
generano equilibrio e benessere.

*A constant dialogue between indoors and  
outdoors. Shapes in harmony with the natural  
environment that create balance and well-being.*

TABULA #11

2023



TABULA

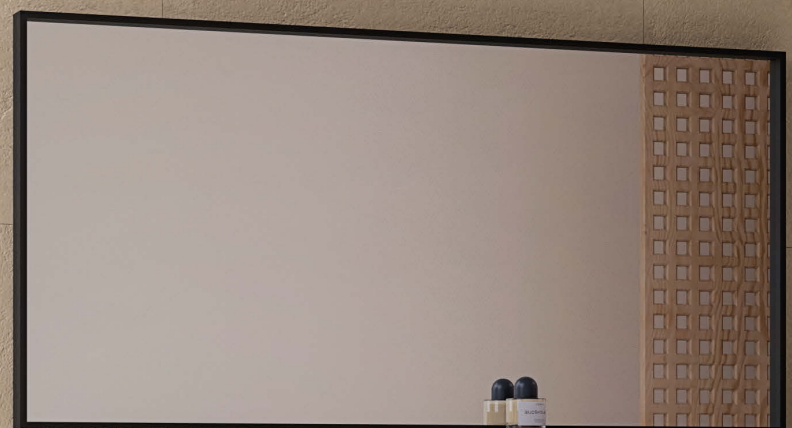

COMPAB

TABULA #12

2023





La collezione Tabula offre ampie superfici d'appoggio per soluzioni di arredo comode e funzionali.

*The Tabula collection offers large surfaces for comfortable and functional furnishing solutions.*







## TABULA

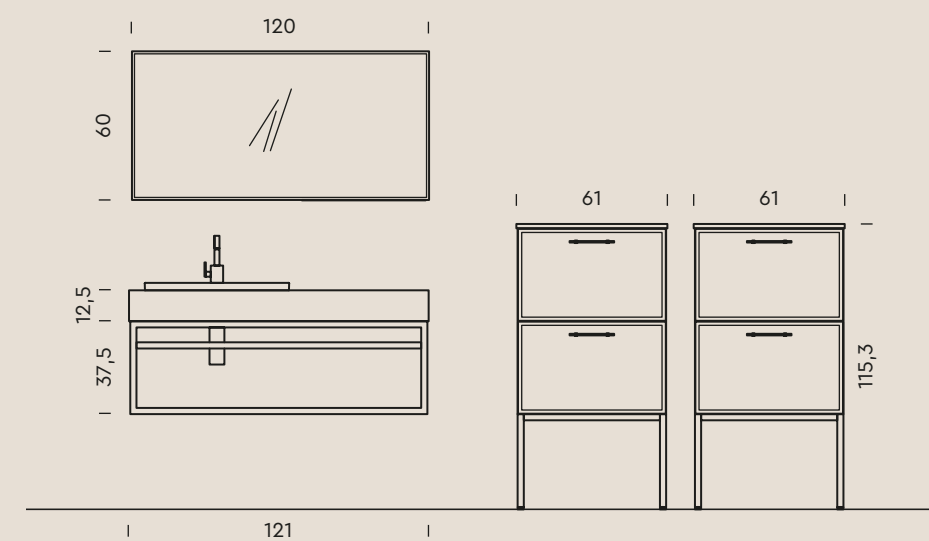

## COMP. TB12

Scocca e frontali: 837 rovere mais.  
 Lavabo incasso soprapiano "Civita" in ceramica nero opaco.  
 Piano in legno sp. 12,5 cm, finitura 845 rovere puro.  
 L 121+61+61 x P 51/38 cm

*Structure and doors: 837 "mais" oak.  
 "Civita" over-counter washbasin in matt black ceramic.  
 Wood top 12.5 cm th., "845 puro oak" finish.  
 W 121+61+61 x D 51/38 cm*

COMPAB

TABULA #12



Una costellazione di elementi si posa con leggerezza nello spazio. Una lama di luce ne rivela la complessa semplicità.

*A constellation of elements dwells lightly in the space. A blade of light reveals its complex simplicity.*





**TABULA** Caratteristiche tecniche / *Technical features*

**Scocca:**  
in truciolare CARB P2 impiallacciato,  
finitura 837 rovere mais.

**Frontali:**  
con telaio in massello e pannello  
interno in MDF impiallacciato,  
finitura 837 rovere mais.

**Structure:**  
in CARB P2 veneered chipboard,  
finish 837 "mais" oak.

**Doors:**  
with solid wood frame  
and veneered MDF panel,  
finish 837 "mais" oak.

**TABULA** Caratteristiche tecniche / *Technical features*

**Maniglia di serie:** in ghisa  
cod. 703 nero

**Standard handle:** in cast iron  
cod. 703 black



**Maniglia aggiuntiva:** in alluminio  
cod. 702 nero

**Extra handle:** in aluminium  
cod. 702 black



## TABULA Composizioni / Arrangements

02 &gt; 09

#TB01

Scocca e frontali: 837 rovere mais.  
Lavabo incasso sopra piano "S20"  
in ceramica bianco lucido.  
Piano in quarzo-resina sp. 1,3 cm, finitura 9C  
Terrazzo black.

Structure and doors: 837 "mais" oak.  
"S20" over-counter washbasin in gloss white  
ceramic.  
Top in quartz-resin 1.3 cm th., "9C Terrazzo  
black" finish.

L/W 96+71+71 x P/D 51/38 cm

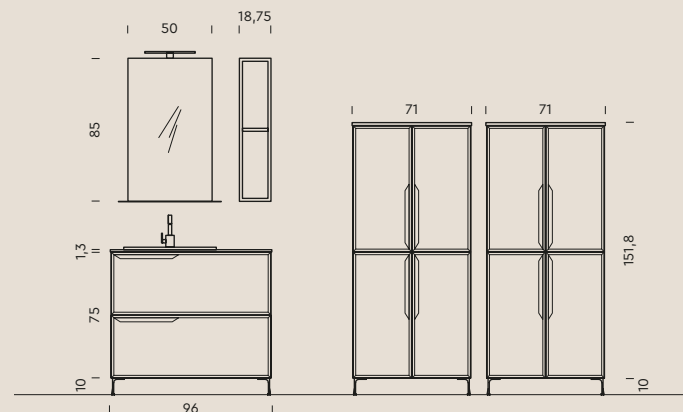

## TABULA Composizioni / Arrangements

28 &gt; 35

#TB04

Scocca e frontali: 837 rovere mais.  
Lavabo in appoggio "Bologna-N" in ceramica  
nero opaco.  
Piano in quarzo-resina sp. 1,3 cm, finitura 9A  
Terrazzo grey.

Structure and doors: 837 "mais" oak.  
"Bologna-N" countertop washbasin in matt  
black ceramic.  
Top in quartz-resin 1.3 cm th., "9A Terrazzo  
grey" finish.

L/W 146+85 x P/D 51/16 cm

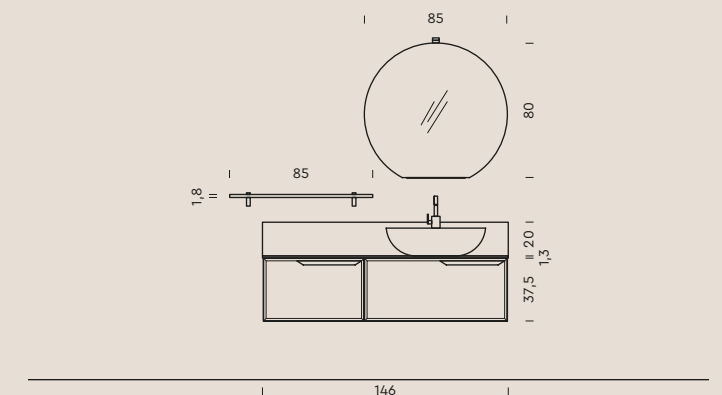

12 &gt; 19

#TB02

Scocca e frontali: 837 rovere mais.  
Lavabo in appoggio "Roma" in ceramica  
bianco opaco. Piano e alzata posteriore  
in gres sp. 1,3 cm, finitura 29 Ardesia bianco.

Structure and doors: 837 "mais" oak.  
"Roma" countertop washbasin in matt  
white ceramic. Top and back upstand in  
stoneware 1.3 cm th., "29 Ardesia bianco"  
finish.

L/W 70+141 x P/D 20,8/51 cm

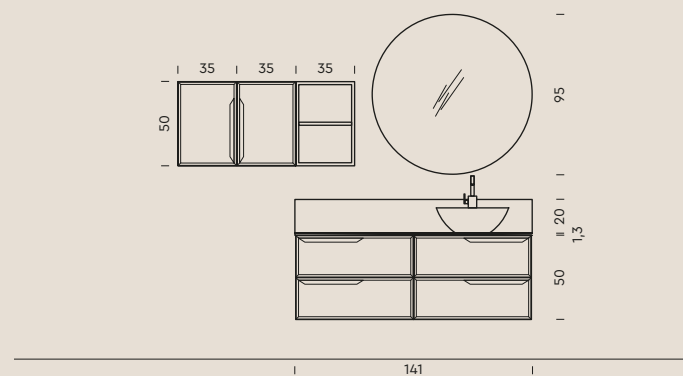

38 &gt; 45

#TB05

Scocca e frontali: 837 rovere mais.  
Piano con vasca integrata "Itaca 50" in Tekor  
sp. 1,3 cm, vasca doppia.

Structure and doors: 837 "mais" oak.  
"Itaca 50" top with integrated basin in Tekor  
1.3 cm th., double basin.

L/W 140+191 x P/D 20,8/51 cm

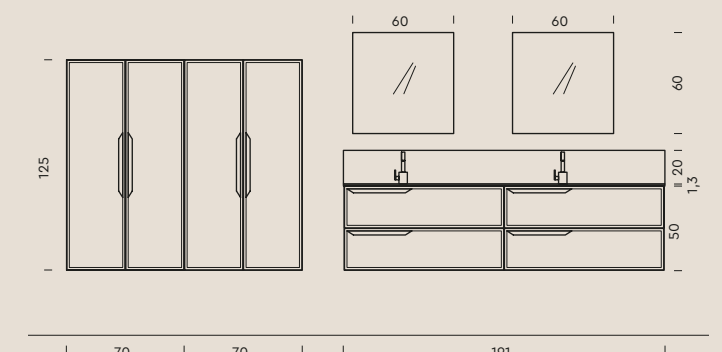

20 &gt; 27

#TB03

Scocca e frontali: 837 rovere mais.  
Piano con vasca integrata "ES 50" in gres  
sp. 12,5 cm, vasca piccola, finitura 28 Ardesia  
nero.

Structure and doors: 837 "mais" oak.  
"ES 50" top with integrated basin in  
stoneware 12.5 cm th., small basin,  
"28 Ardesia nero" finish.

L/W 71+71+106 x P/D 51/38 cm

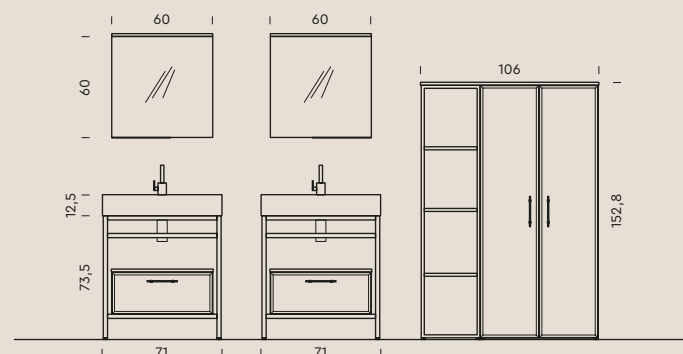

46 &gt; 51

#TB06

Scocca e frontali: 837 rovere mais.  
Lavabo consolle "Ibiza" in Minera-Kolor  
(H5 datura) L 120,5 cm.

Structure and doors: 837 "mais" oak.  
"Ibiza" console washbasin in Minera-Kolor  
(H5 datura) W 120.5 cm.

L/W 120,5+85+38 x P/D 51,5/12/38 cm

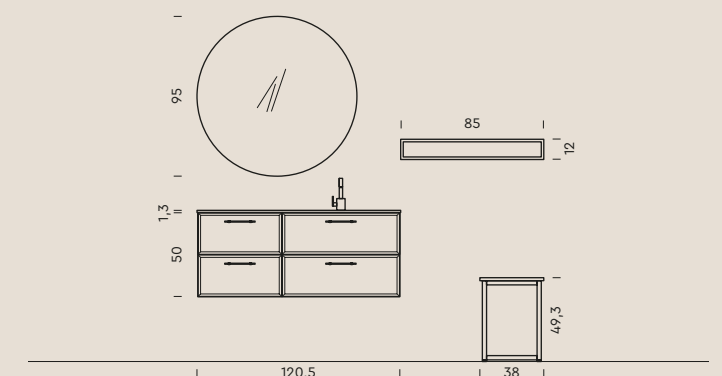



## TABULA Composizioni / Arrangements

54 &gt; 61

#TB07

Scocca e frontali: 837 rovere mais.  
Lavabo in appoggio "Atene" in gres,  
finitura 2K Korten.

Structure and doors: 837 "mais" oak.  
"Atene" countertop washbasin in  
stoneware, "2K Korten" finish.

L/W 46+46+60,2+60 x P/D 46/20,8 cm

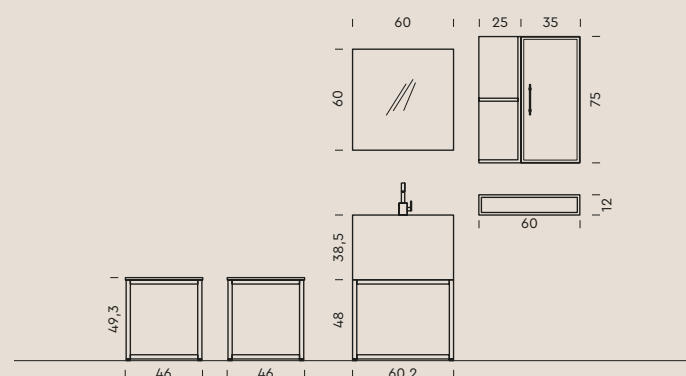

## TABULA Composizioni / Arrangements

82 &gt; 89

#TB10

Scocca e frontali: 837 rovere mais.  
Lavabo in appoggio "Logyn" in gres,  
finitura 2K Korten.  
Piano in gres sp. 1,3 cm, finitura 2K Korten.

Structure and doors: 837 "mais" oak.  
"Logyn" countertop washbasin in stoneware,  
"2K Korten" finish.  
Top in stoneware 1.3 cm th., "2K Korten"  
finish.

L/W 176 x P/D 51 cm

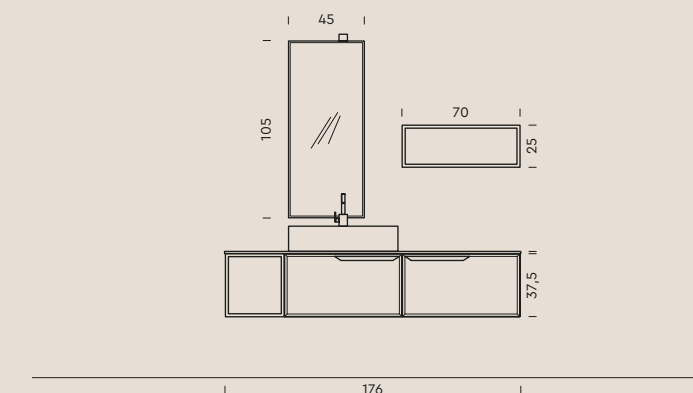

62 &gt; 71

#TB08

Scocca e frontali: 837 rovere mais.  
Lavabo consolle "Bliz" in Mineralguss bianco  
lucido L 140,5 cm.

Structure and doors: 837 "mais" oak.  
"Bliz" console washbasin in gloss white  
Mineralguss W 140.5 cm.

L/W 140,5+35 x P/D 51,5/37 cm

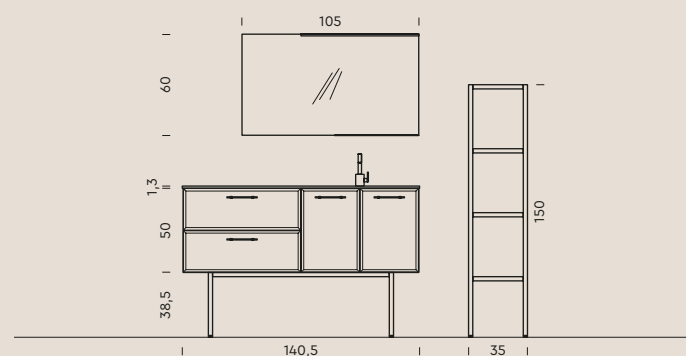

90 &gt; 97

#TB11

Scocca e frontali: 837 rovere mais.  
Piani con vasca integrata "Samo 50" in Tekor  
sp. 12,5 cm, vasca piccola.

Structure and doors: 837 "mais" oak.  
"Samo 50" tops with integrated basin  
in Tekor 12.5 cm th., small basin.

L/W 86+121+141 x P/D 51/38 cm

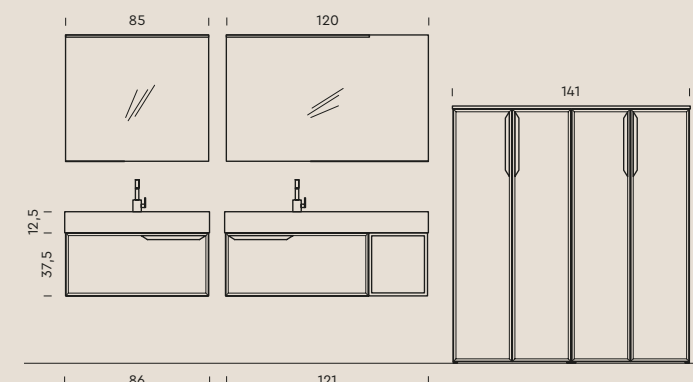

72 &gt; 79

#TB09

Scocca e frontali: 837 rovere mais.  
Lavabo in appoggio "Firenze" in ceramica  
nero opaco.  
Piano in quarzo-resina sp. 1,3 cm, finitura  
9C Terrazzo black.

Structure and doors: 837 "mais" oak.  
"Firenze" countertop washbasin in matt  
black ceramic.  
Top in quartz-resin 1.3 cm th., "9C Terrazzo  
black" finish.

L/W 85+71+60 x P/D 37/51/16 cm

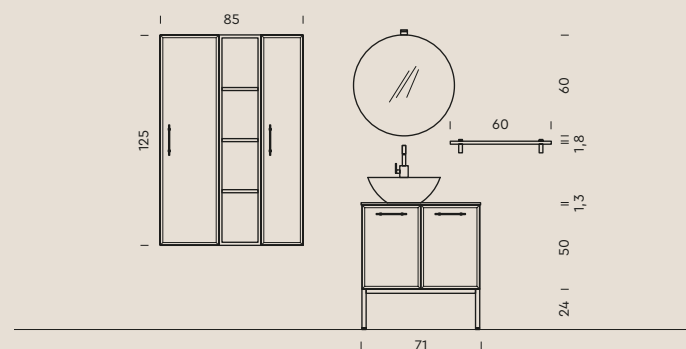

98 &gt; 105

#TB12

Scocca e frontali: 837 rovere mais.  
Lavabo incasso soprapiano "Civita"  
in ceramica nero opaco.  
Piano in legno sp. 12,5 cm, finitura 845  
rovere puro.

Structure and doors: 837 "mais" oak.  
"Civita" over-counter washbasin in matt  
black ceramic.  
Wood top 12.5 cm th., "845 puro oak"  
finish.

L/W 121+61+61 x P/D 51/38 cm

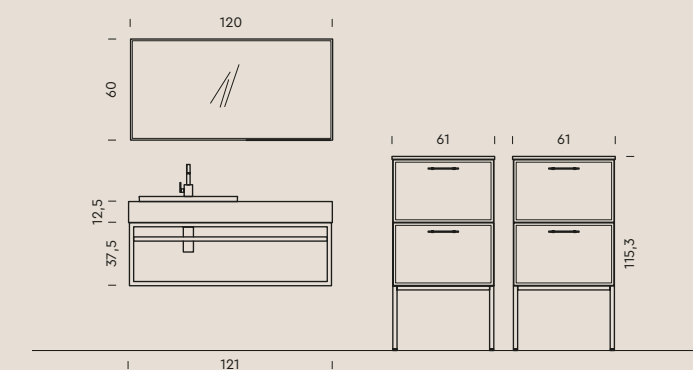





Compab srl  
Viale Lino Zanussi, 9  
33070 Maron di Brugnera  
Pordenone - Italy

Tel. +39 0434 624920  
Fax +39 0434 624679

[info@compabilbagno.it](mailto:info@compabilbagno.it)  
[www.compab.it](http://www.compab.it)





**Compab srl**

Viale Lino Zanussi, 9  
33070 Maron di Brugnera  
Pordenone - Italy

Tel. +39 0434 624920  
Fax +39 0434 624679

[info@compabilbagno.it](mailto:info@compabilbagno.it)  
[www.compab.it](http://www.compab.it)