



TEMASDOS

Tradición Mediterránea

TEMASDOS

La experiencia del confort.

Somos expertos en confort.

Nuestro recorrido como fabricantes de tapicería suma más de medio siglo de experiencia artesana y recoge lo mejor del legado artesanal de Valencia.

Sofás y butacas hechos con atención al detalle, diseñados pensando siempre en el cliente, priorizando lo que verdaderamente importa: la calma y el descanso en el hogar.





Nuestra empresa

*Isabel Aguilar e Ismael Gallego
reformulan el pequeño negocio familiar
de tapicería artesanal en 2010
y crean la firma TEMASDOS.*

*Su éxito radica en la combinación de
la manufactura artesanal de toda la vida
con las herramientas tecnológicas actuales,
acercando al público las tendencias,
sin dejar de lado el confort.*

*La excelente relación calidad-precio,
la durabilidad de nuestros productos,
y una impecable atención al cliente
son los pilares de TEMASDOS.*



La localización

Para la realización de las fotografías de gran parte de este catálogo elegimos una localización muy especial: El Telar de Miguel Martí. Un telar valenciano del siglo XII reconvertido en un espacio contemporáneo.

Resume lo mejor de nuestra filosofía: rescatar y conservar lo más bello de nuestra artesanía y tradición local, pensando en la sostenibilidad y el mañana.



ÍNDICE

ÁGORA	14	NADIR	86
ALPHA	20	OMEGA	92
ALTANO	24	PLATEA	94
ARES	30	SIGMA	106
BARINE	34	SIROCCO	110
BERTINA	40	TASSOS	114
BRUMA	46	TITA	116
CORAL	48	TUCSON	118
CORALINA	54	TUNDRA	128
CRONO	56	YUTE	132
DINO	60	ZENITH	138
EROS	62	ZONDA	144
GAMMA	64	CALA	150
GIANT	68	ISLA	154
LINO	74	REMO	158
MEMPHIS	78	POUFS	162
MISTRAL	84		



SOFÁS Y BUTACAS

Ágora

Ágora es un sistema modular de infinitas posibilidades.

*Un sofá atemporal gracias a su excepcional elegancia
alejada de cualquier estridencia.*

*Ofrece dos tipologías de respaldos distintos:
un cojín articulado con respaldo abatible, o un mullido cojín
tradicional con efecto de envolvente plumón.*















Alpha

Alpha aporta personalidad y sofisticación en los detalles.

El delgado equilibrio de sus patas, la forma redondeada de sus brazos o el detalle de la costura de su respaldo, aportan un estilo inimitable y una decidida apuesta por interiores con carácter.

Sus respaldos y asientos son desenfundables y ofrecen una de las sentadas más blandas de la colección Temasdos para amantes de la sentada mullida y acogedora.



*“La PERSONALIDAD
se encuentra en los detalles”.*



Altano

Altano es un sofá de pata alta que aporta un estilo atemporal. Sus generosas proporciones en brazos y la profundidad de su asiento le dotan de gran confort y una silueta robusta.

La línea sobria de su diseño es garantía de durabilidad en el diseño. Los cojines desenfundables del asiento y respaldo de efecto plumón crean una sentada alta y mullida para un confort excepcional.









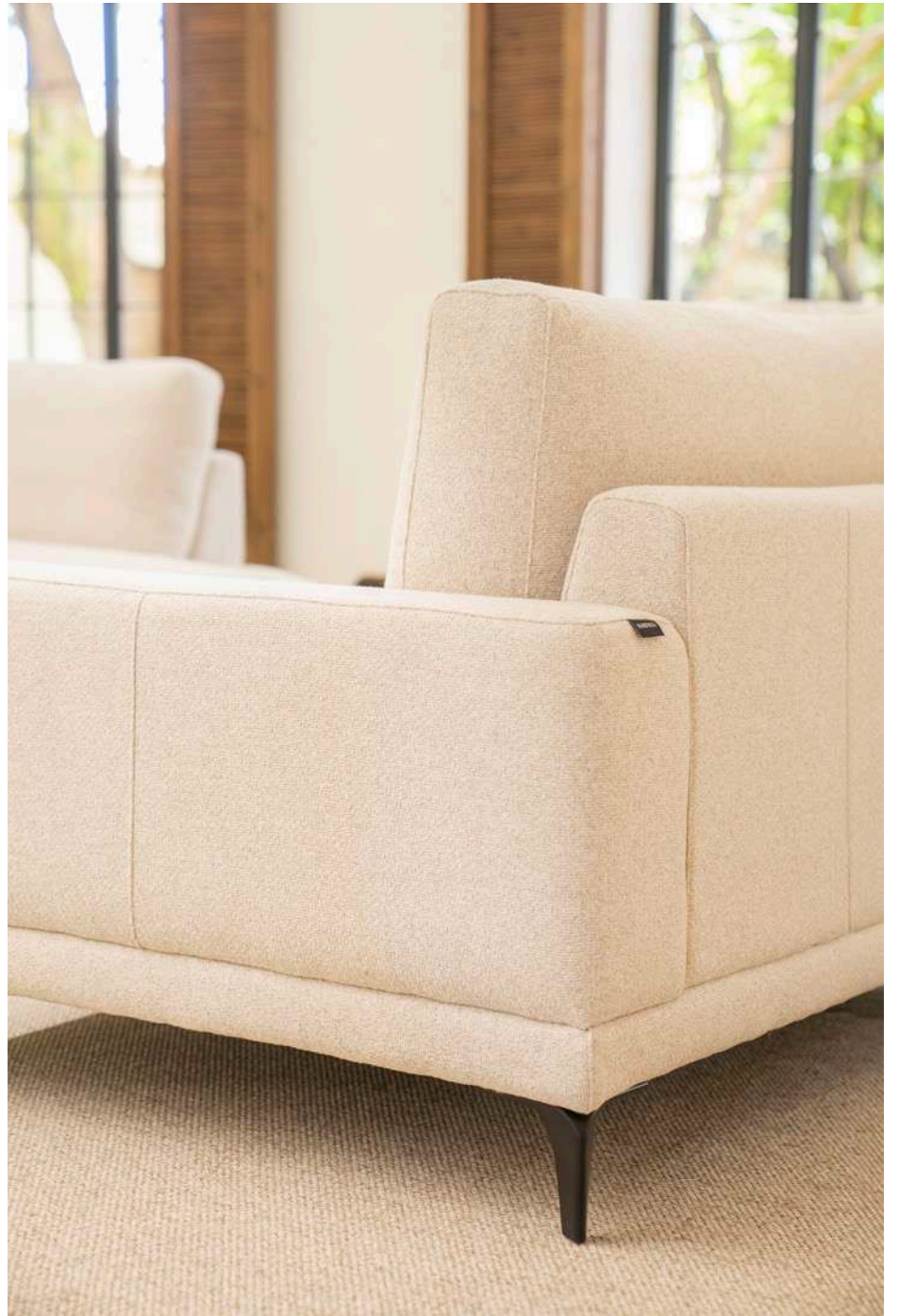

Ares

Ares pretende ser un básico atemporal, una butaca de acento, práctica, confortable y de reducido tamaño.

La butaca Ares es ideal para ser utilizada en salas de espera, habitaciones de hotel, complemento para dormitorios o habitaciones de reducidas dimensiones.









Barine







El sofá Barine es un equilibrio de diseño y confort.

Sus asientos bajos y firmes se inspiran en el elegante estilo italiano. Conservan la comodidad gracias a su discreto cabezal abatible y su cuidada inclinación lumbar.



“Un sofá concebido para amantes del DISEÑO con mayúsculas”.



Bertina

Un clásico que perdura a través de los años.

Una colección que ofrece numerosas combinaciones de acabados, longitudes y fondos.

Bertina es tan configurable y sus opciones tan amplias que se convertirá en el traje a medida perfecto para tu hogar.











*Los complementos de Bertina
se vuelven imprescindibles
para configurar el descanso ideal.*



Bruma



Bruma es una butaca de acento ideal para estancias pequeñas, dormitorios, habitaciones de hotel o espacios lounge.

Gracias a la altura de su asiento, similar a la de cualquier silla, puede ser utilizada como sillón de escritorio o sillón de comedor.

Coral



El sofá Coral sigue la tendencia de los muebles de formas curvas y suaves que abandonan la austeridad.

Una sentada alta y firme, ideal para salas de espera, lobbys o estancias donde el estilo se convierte en esencial.







*“La CURVA aporta
la belleza de lo orgánico,
una sensación ENVOLVENTE
de cálida acogida.
Es el fin del minimalismo”.*



Coralina

La butaca Coralina es visualmente envolvente.

Una sentada alta y firme, ideal para salas de espera, lobbys o estancias que transmitan relajación y suavidad.







Crono

La butaca Crono pretende hacer desaparecer el tiempo.

*Una butaca cuyo confort sea tan especial
que la convierta en tu rincón favorito de lectura,
de audición de música, incluso de trabajo.*

*Un sencillo pero eficaz diseño
para amantes de lo práctico y confortable.*







Dino

*“Su asiento móvil
de formas rectas y lineales
le aporta cierto aire RETRO”.*

Eros



Una butaca relax opulenta y envolvente.

Su reposapiés oculto y su respaldo articulado pueden ser activados de manera manual o mediante botonera electrónica.

Permite alojar una batería recargable.



Gamma

Un sistema modular que nunca pasará de moda.

Mullidos cojines de asiento y respaldo desenfundables.

*Al no tener costuras delanteras su asiento es reversible,
lo que le otorga larga durabilidad.*





*BÁSICO
ELEMENTAL
IMPRESINDIBLE*





Giant











Un sofá de dimensiones extraordinarias.

Asientos extra profundos ideales para grandes espacios, familias numerosas, o simplemente para disfrutar de un sofá generoso con un confort extraordinario.

Incluye también una versión con menor profundidad para espacios más reducidos.

Lino







*Su apariencia clásica
esconde un secreto:
ASIENTOS EXTRAIBLES.*

*Su RESPALDO se mantiene suspendido
en el aire como por arte de magia
mientras el asiento se DESLIZA
gracias a un mecanismo
único en el mercado.*





Memphis







*Un CLÁSICO del diseño modernizado.
Un asiento firme y alto
con un respaldo generoso
para amantes de lo PRÁCTICO.*





Mistral



Un sofá relax con respaldo y reposapiés articulados accionables mediante botonera oculta entre los asientos, con opción a botonera en el brazo con puerto USB.

Sentada semifirme y respaldo mullido desenfundable.





Nadir





Cabecero abatible.

Sentada firme.







*La elegante pata metálica
le aporta CONTEMPORANEIDAD.*

Omega



Una butaca relax de estética limpia y contemporánea con reposapiés oculto y respaldo articulado.

Su movimiento puede realizarse manual o electrónicamente, enchufada a la red o con batería recargable.



Platea (pata alta)

Platea es un sistema modular de delicadas formas orgánicas.

*El sofá se presenta en dos versiones en su base,
a suelo y con pata alta de madera,
con numerosas configuraciones de cojines para los respaldos.*

*Un sofá que sigue la tendencia del diseño curvo
sin renunciar al auténtico confort en el hogar.*













Platea (pata baja)





*“La forma REDONDEADA
es la TENDENCIA del momento”.*







Sigma

El sofá relax Sigma destaca por su línea recta y depurada.

*El secreto de su éxito lo constituyen
su cabecero articulado y el discreto reposapiés oculto
que se acciona mediante pulsador eléctrico situado en el brazo.*

*Descubre un amplio abanico de opciones de patas y brazos
para configurar tu descanso ideal.*







Asientos relax

Cabecero articulado

Botonera eléctrica

Reposapiés desplegable

5 patas a elegir

Sirocco

*Un sistema modular fresco y contemporáneo
de generosas proporciones.*







*SIROCCO se fabrica con espuma
reciclada VEFER, única en el mercado,
y cuenta con decenas de tejidos
reciclados para tapizar.*

*SIROCCO
es una gran apuesta por la
SOSTENIBILIDAD.*

Tassos

*Una butaca relax mullida y opulenta
de formas suaves y generosas.*

*Su reposapiés oculto y su respaldo articulado
pueden ser activados de manera manual
o mediante botonera electrónica.*

Permite alojar una batería recargable.



Tita



*Una butaca de acento giratoria
sobre una base de aspa metálica.*

*Ideal como complemento
de salones y espacios lounge.*





Tucson





Cabecero articulado



Asiento extraíble









Tundra



*Un sofá relax de última generación
activable mediante tecnología Bluetooth.
Su mecanismo logra desplegar
la posición más horizontal del mercado.*

*Sus finos cabeceros articulados
de manera electrónica
le confieren una contemporaneidad
insólita en un sofá relax.*













Yute

*“Un sofá extensible de cabezal articulado
con una silueta actual y contemporánea.
Todo un hallazgo.”*







*“Hasta 170 cm
de extensión de asiento”.*







Zenith

Zenith es un sofá relax de estética limpia y arquitectónica que dota de personalidad a cualquier ambiente.

Gracias a su cabecero abatible y su reposapiés oculto, Zenith une el confort de un sofá de relax con una estética depurada y minimalista.









Zonda

*Un sofá relax de última generación
activable mediante tecnología Bluetooth.
Su mecanismo logra desplegar
la posición más horizontal del mercado.*

*Sus finos cabeceros articulados
combinan con la delgadez de sus brazos,
optimizando el espacio
de una manera elegante y estética.*









MUEBLES AUXILIARES





Cala







Isla









Remo





Poufs





FICHAS TÉCNICAS

ÁGORA

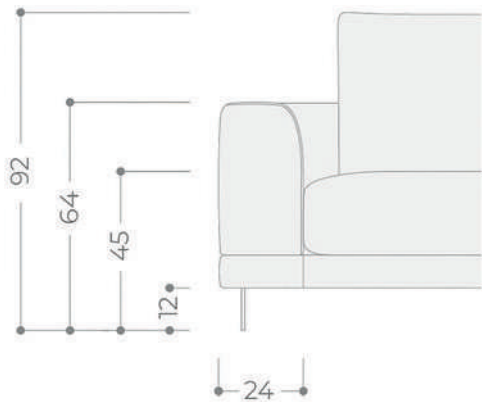

Módulo Ágora con respaldo alto

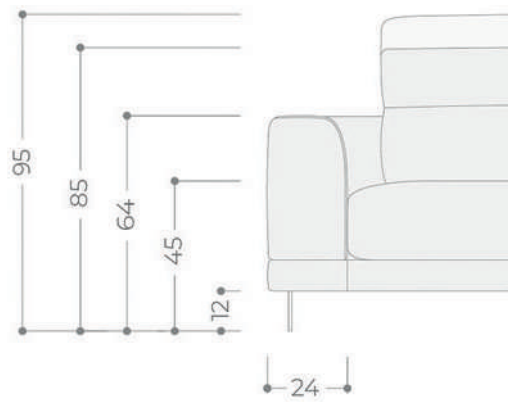

Módulo Ágora con respaldo articulado

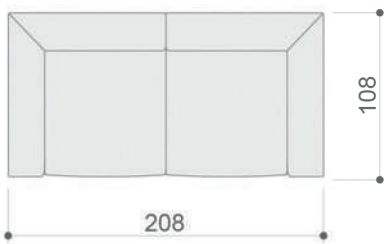

Sofá con 2 brazos

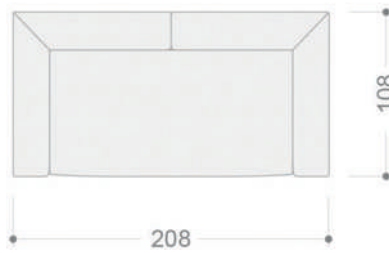

Sofá 2 brazos / Asiento 1 pieza



Sofá 1 brazo / Asiento 1 pieza

ÁGORA

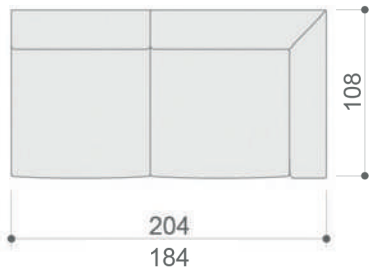

Sofá con 1 brazo

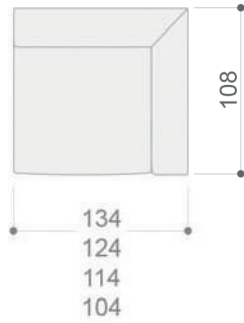

Módulo con 1 brazo

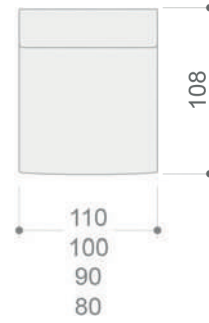

Módulo sin brazos

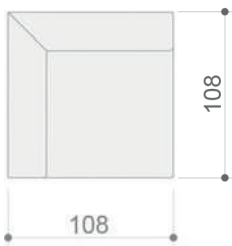

Rincón cerrado

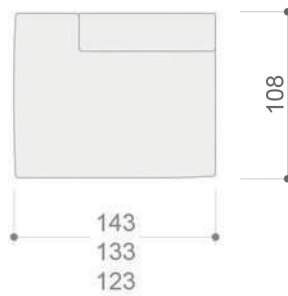

Terminal

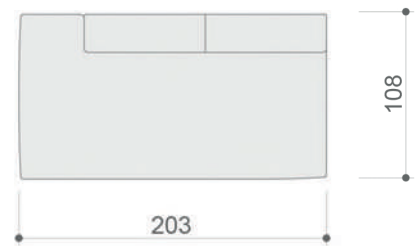

Terminal doble

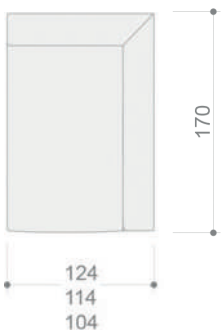

Chaise Longue

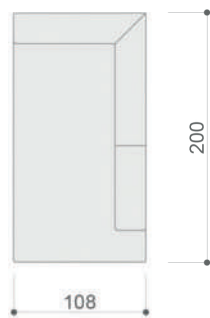

Rincón terminal

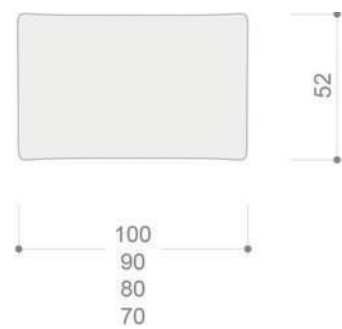

Respaldo pluma con rulo

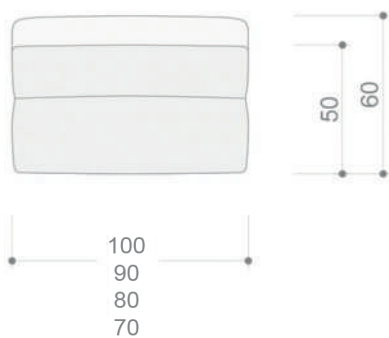

Respaldo pluma articulado

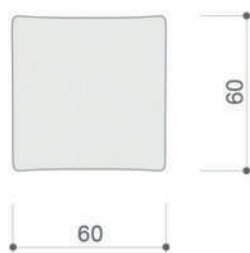

Cuadrante microfibra

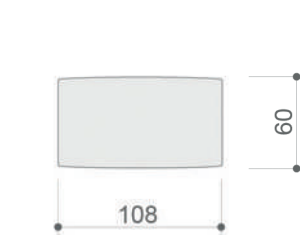

Posapiés terminal

ALPHA



Sofá con 2 brazos



Sofá con 1 brazo

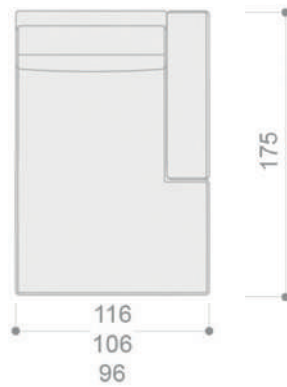

Chaise Longue

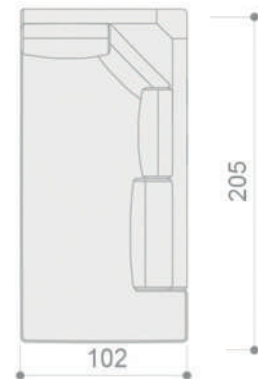

Rincón terminal

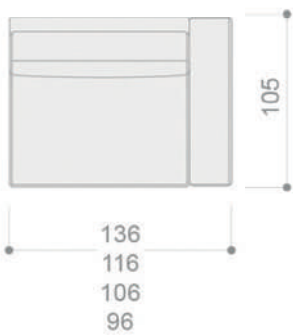

Módulo con 1 brazo

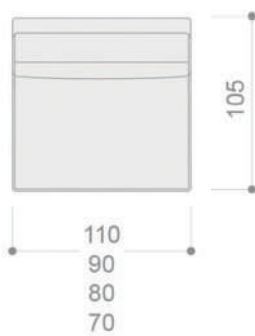

Módulo sin brazos

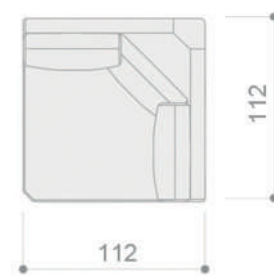

Rincón abierto



Terminal

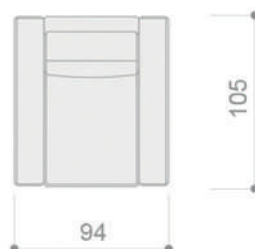

Butaca

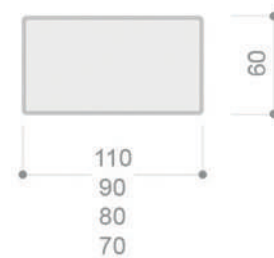

Posapiés

ALTANO

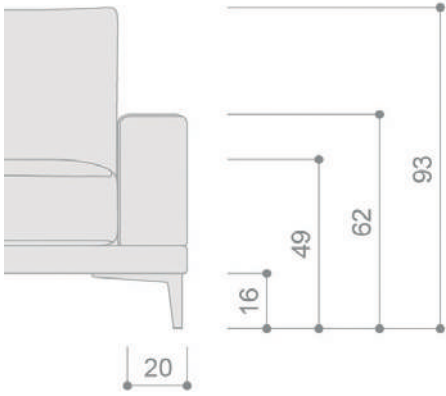

Pata níquel negro 16 cm.

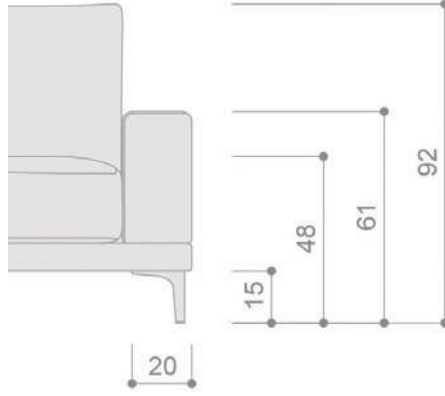

Pata metálica negra mate 15 cm.

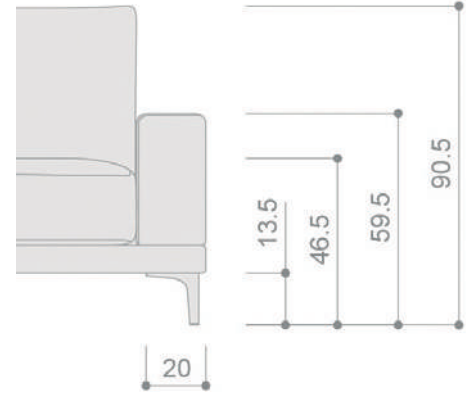

Pata metálica negra mate 13,5 cm.

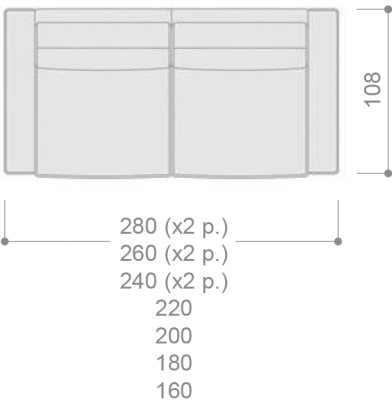

Sofá con 2 brazos

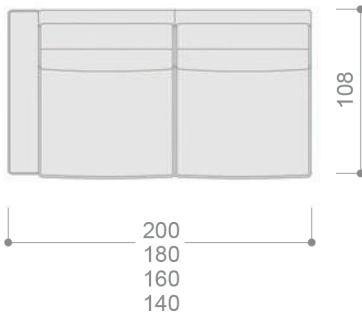

Sofá con 1 brazo

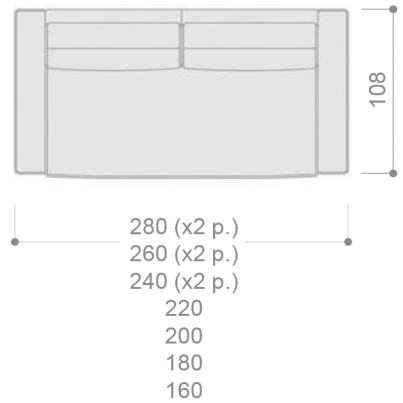

Sofá con 2 brazos/Asiento en 1 pieza

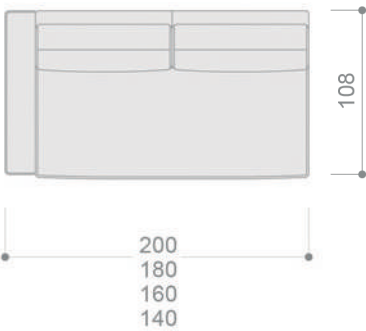

Sofá con 1 brazo/Asiento en 1 pieza

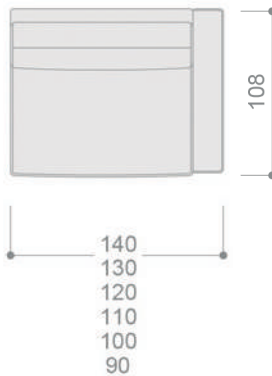

Módulo con 1 brazo

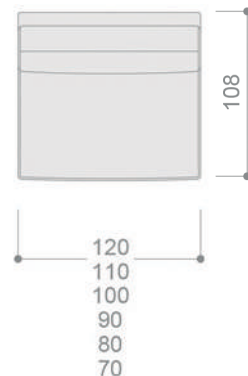

Módulo sin brazos

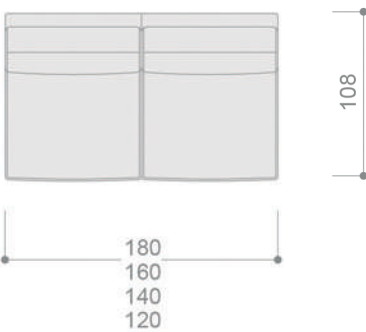

Sofá sin brazos

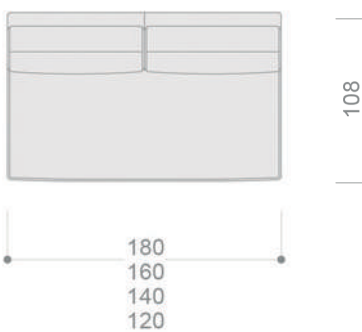

Sofá sin brazos/Asiento en 1 pieza

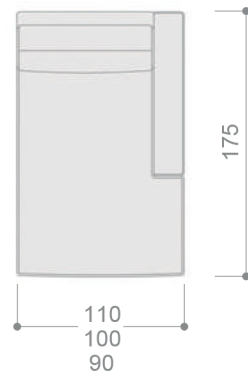

Chaise longue brazo corto

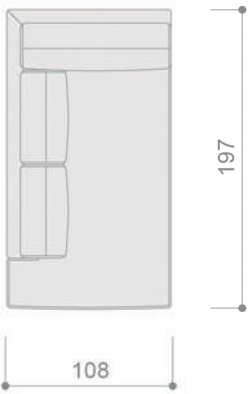

Rincón terminal

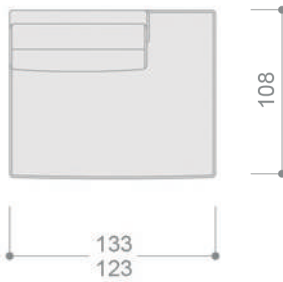

Terminal

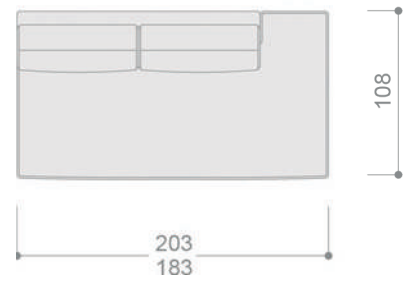

Terminal doble

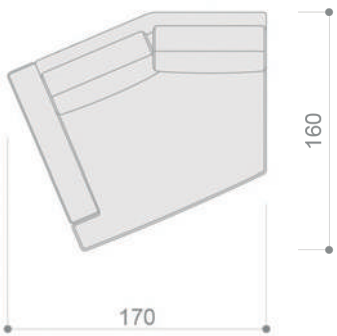

Angular

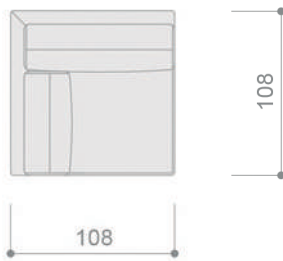

Rincón

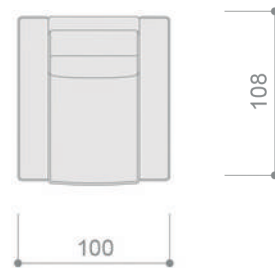

Butaca

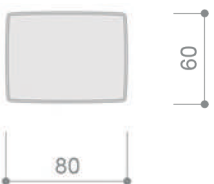

Posapiés rectangular

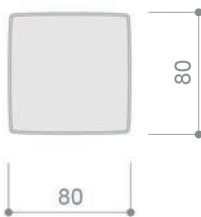

Posapiés cuadrado

ARES

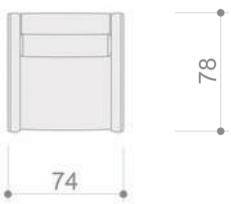
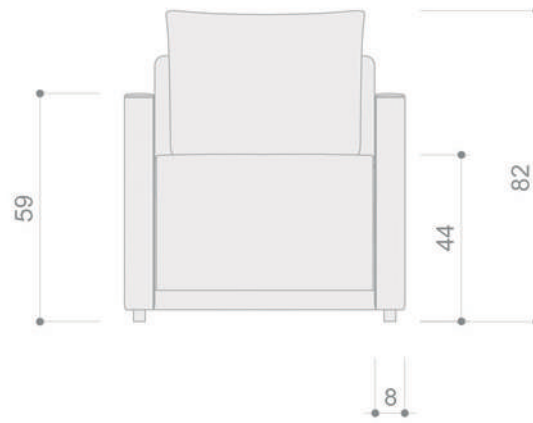

Butaca

BARINE

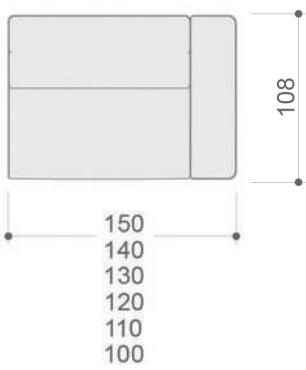
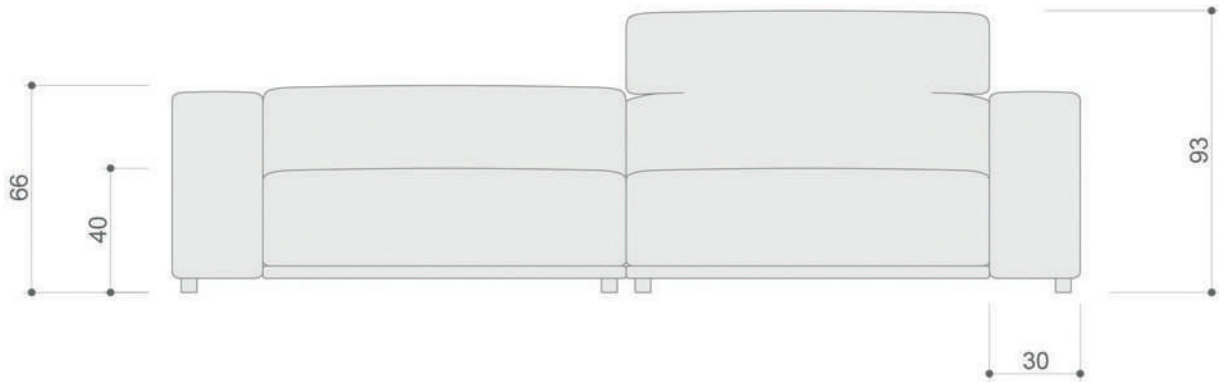

Módulo con 1 brazo

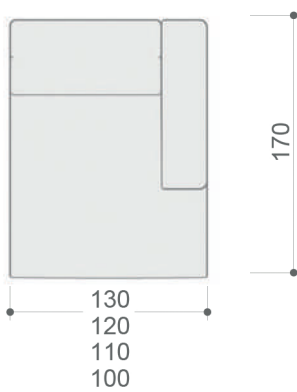

Chaise Longue

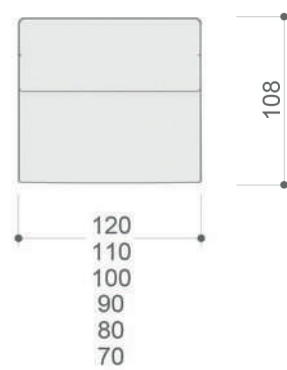

Módulo sin brazos

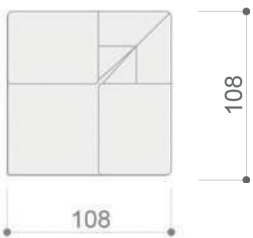

Rincón cerrado

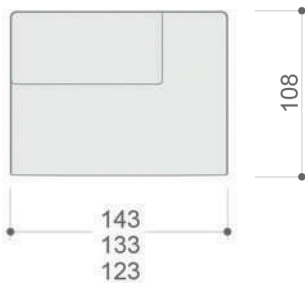

Terminal

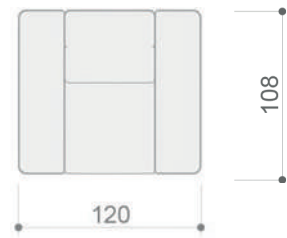

Sillón

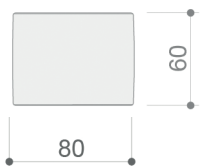

Posapiés 80x60

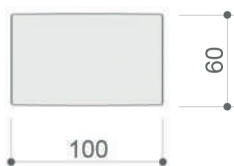

Posapiés 100x60

BERTINA



BERTINA

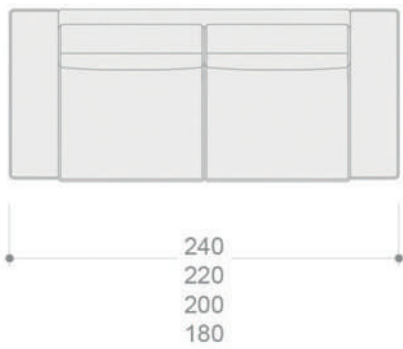

Sofá con 2 brazos



Sofá con 1 brazo

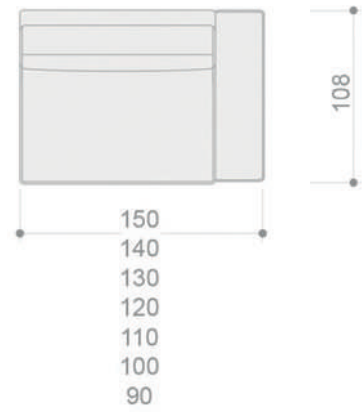

Módulo con 1 brazo

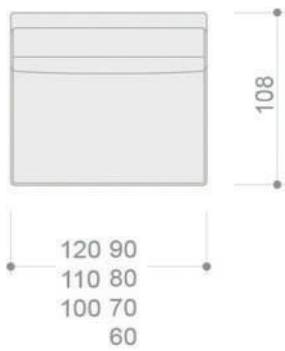

Módulo sin brazos



Sofá sin brazos



Rincón



Rincón terminal
(compatible con bertina little)

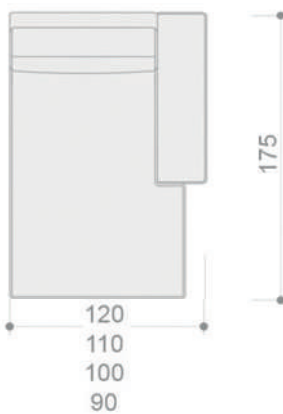

Chaise longue con martillo
(compatible con bertina little)



Chaise longue brazo largo
(compatible con bertina little)

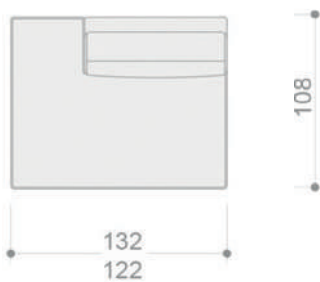

Terminal

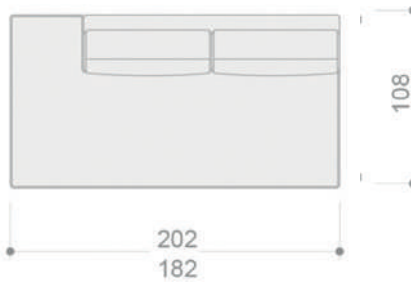

Terminal doble



BERTINA LITTLE

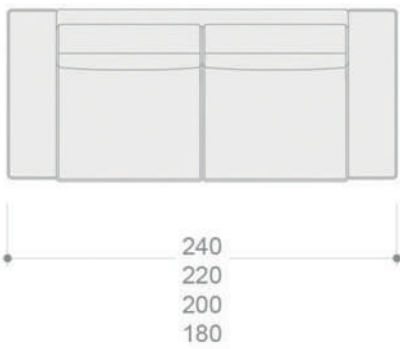

Little sofá 2 brazos

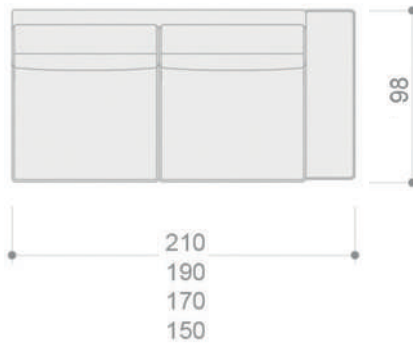

Little sofá 1 brazo

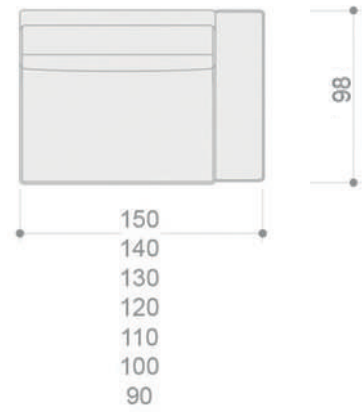

Little módulo con 1 brazo

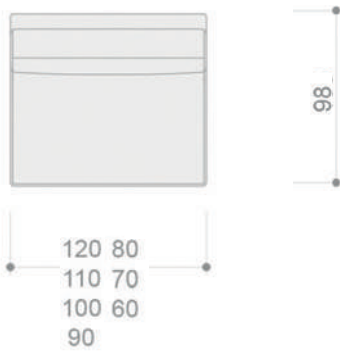

Little módulo sin brazos



Little sofá sin brazos



Little rincón



Little terminal

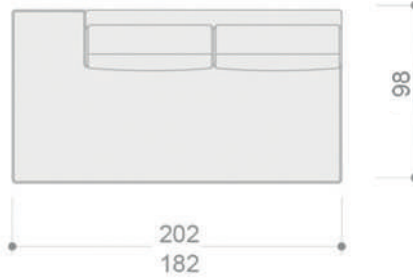

Little terminal doble



Reposapiés rectangular
(compatible con bertina little)

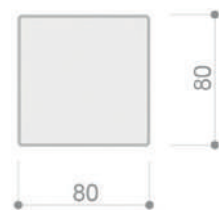

Reposapiés cuadrado
(compatible con bertina little)



Reposapiés con brazo
(compatible con bertina little)

BRUMA

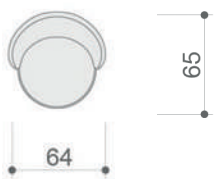
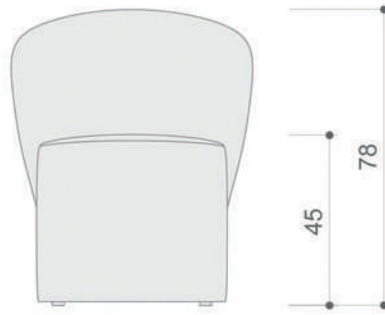

Butaca

SOFÁ CORAL

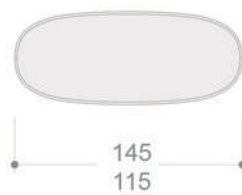
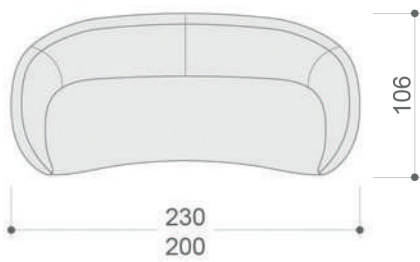
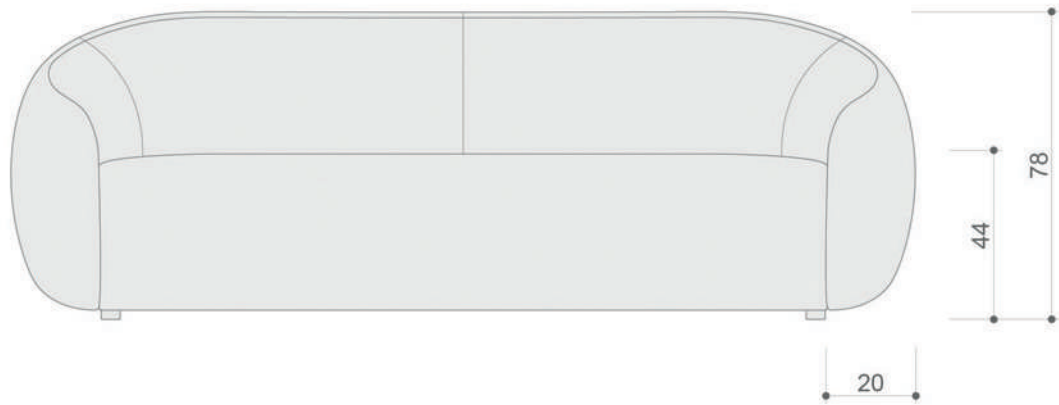

Sofá

Posapiés

BUTACA CORAL

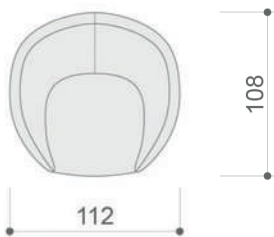
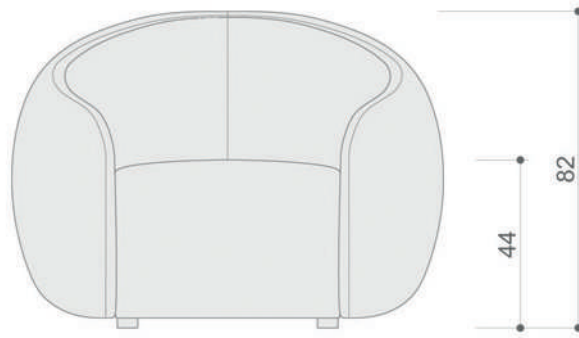

Butaca giratoria

CORALINA

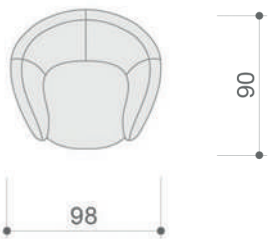
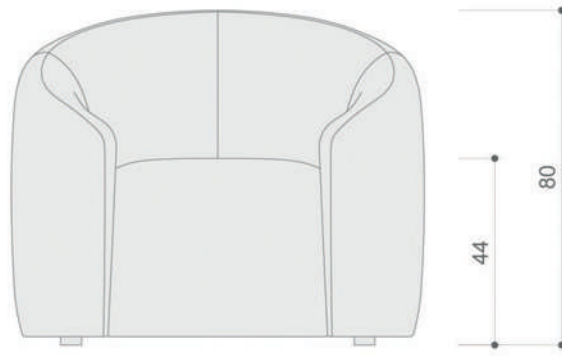

Butaca

CRONO

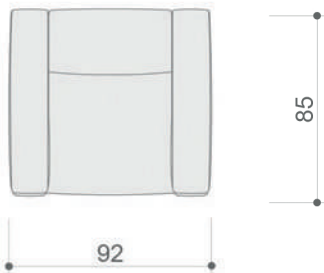
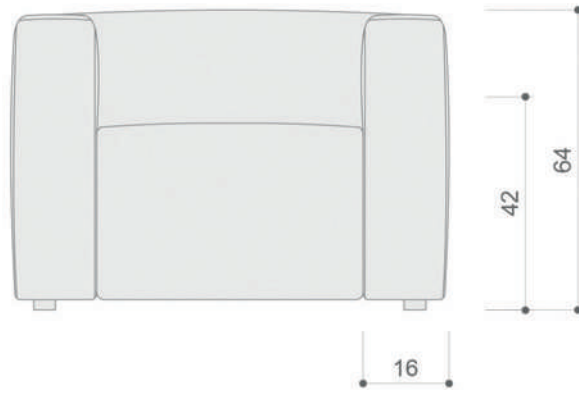

Butaca

DINO



Butaca

EROS

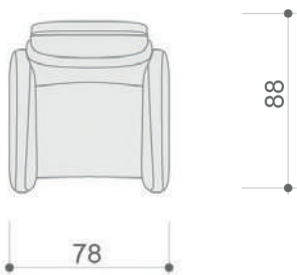
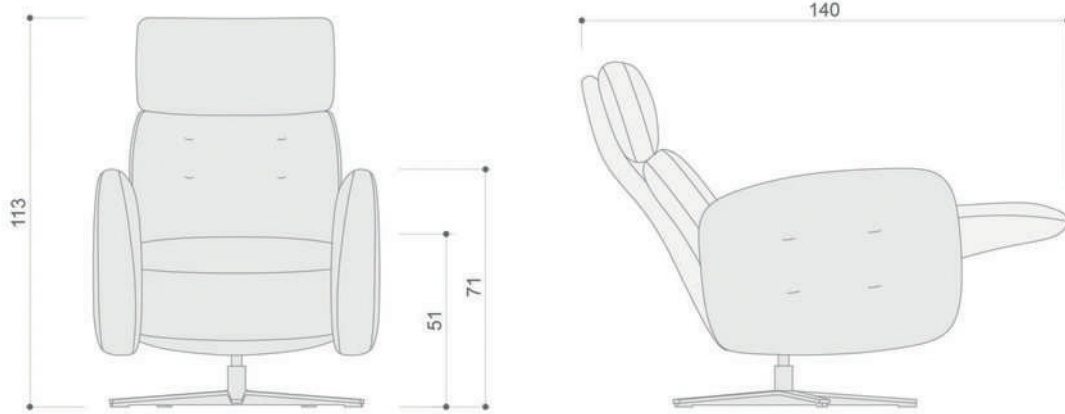

Butaca

GAMMA

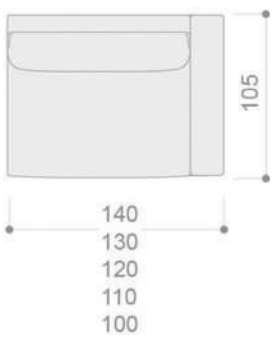
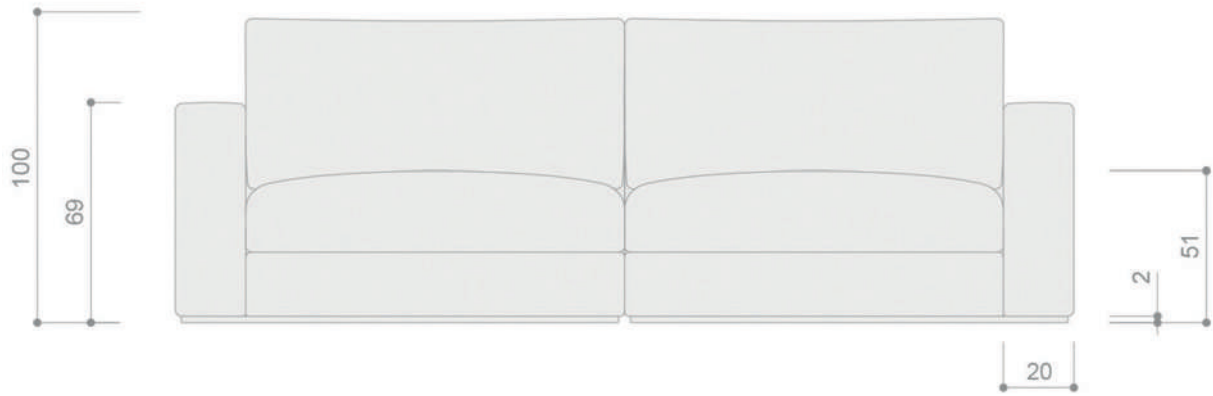

Módulo con 1 brazo

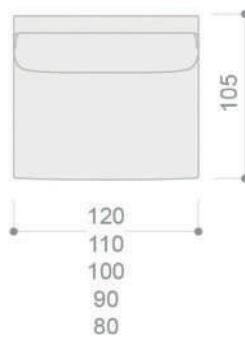

Módulo sin brazos

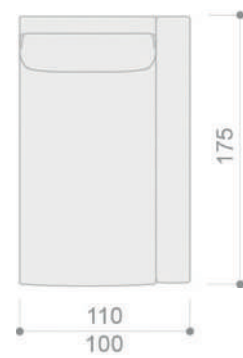

Chaise Longue con brazo largo



Rincón terminal

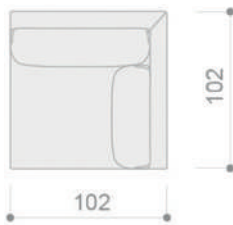

Rincón cerrado



Terminal



Reposapiés rectangular

GIANT

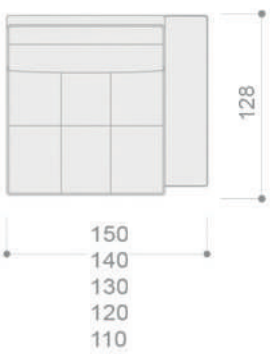

Módulo con 1 brazo

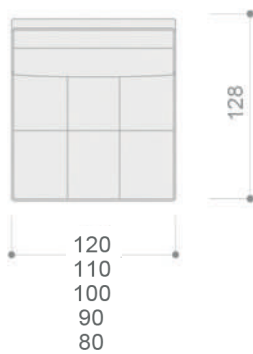

Módulo sin brazos

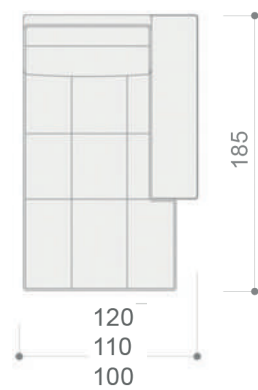

Chaise Longue

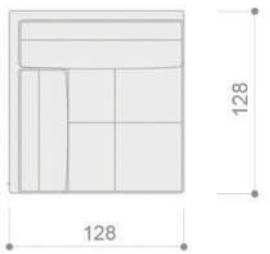

Rincón

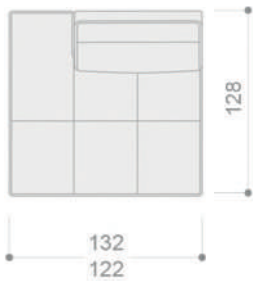

Terminal

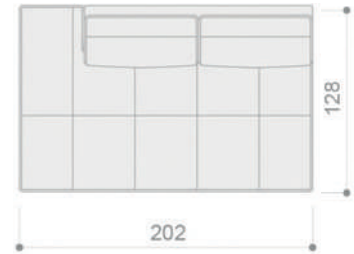

Terminal doble



Little sofá

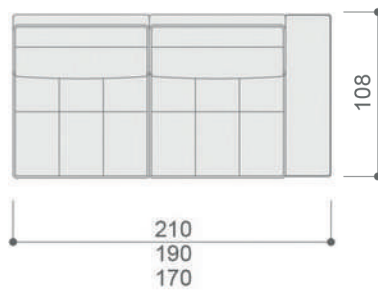

Little sofá con 1 brazo

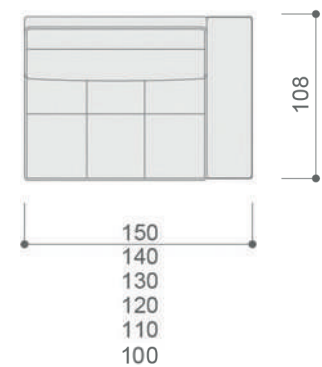

Little módulo con 1 brazo

GIANT

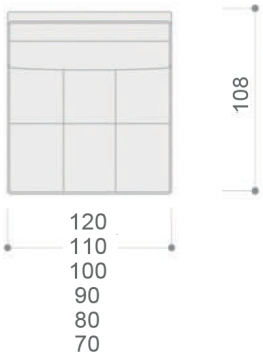

Little módulo sin brazos

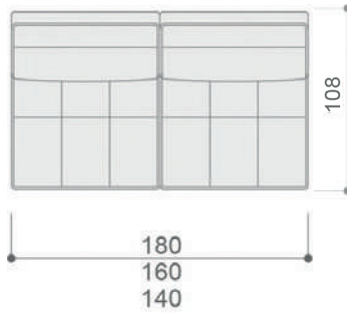

Little sofá sin brazos

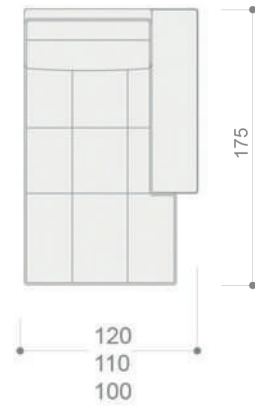

Little Chaise Longue

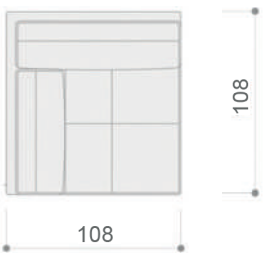

Little Rincón

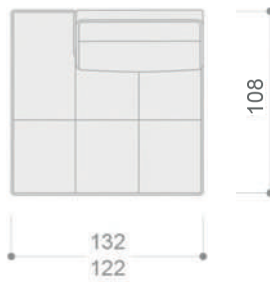

Little Terminal

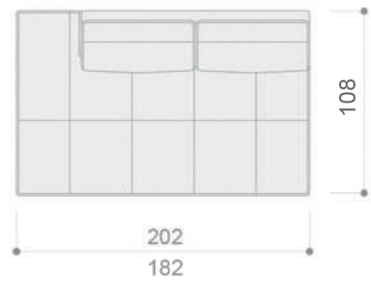

Little Terminal doble

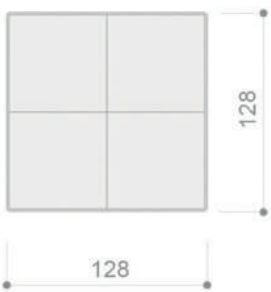

Posapiés cuadrado rincón

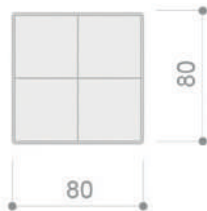

Posapiés cuadrado grande

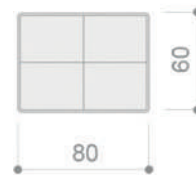

Posapiés rectangular



Posapiés rectangular terminal

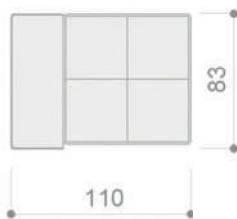

Posapiés con brazo



LINO

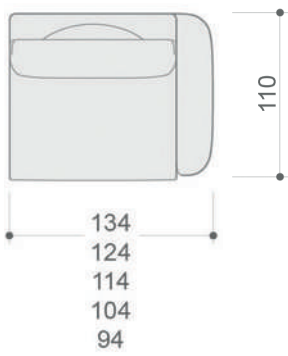
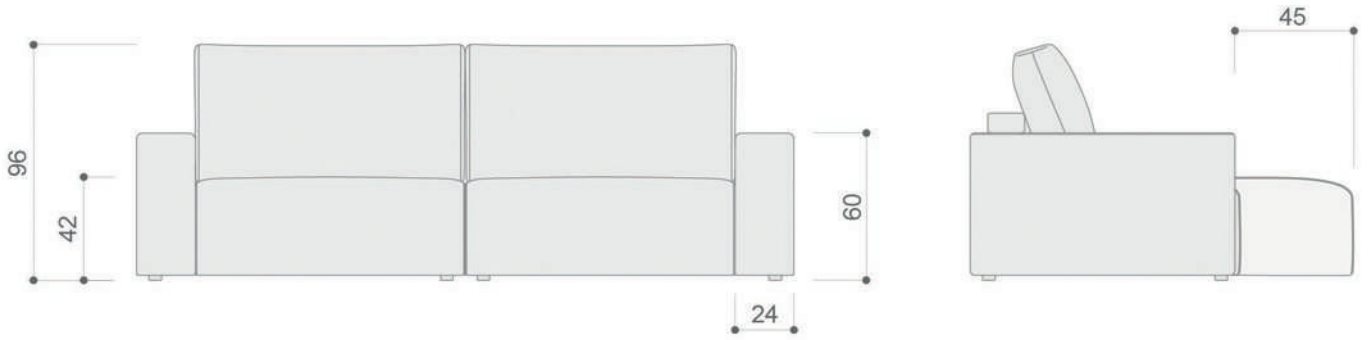

Módulo con 1 brazo

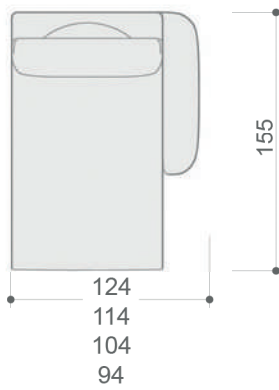

Chaise Longue

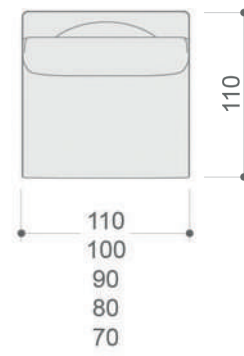

Módulo sin brazos

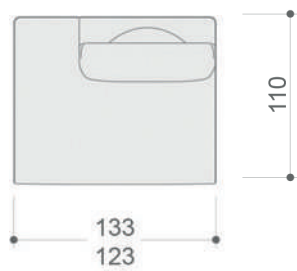

Terminal

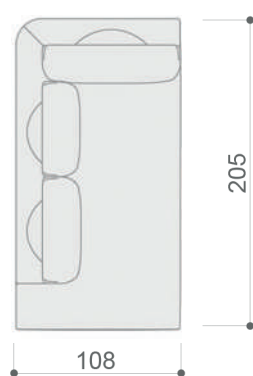

Rincón Terminal

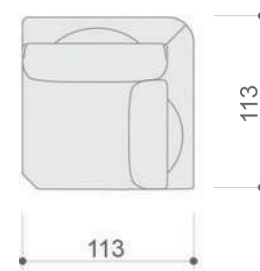

Rincón abierto

MEMPHIS



MEMPHIS



Sofá con 2 brazos



Sofá con 1 brazo

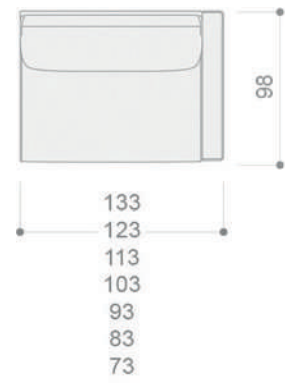

Módulo con 1 brazo

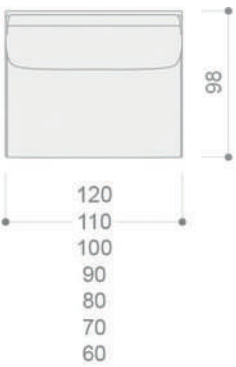

Módulo sin brazos



Sofá sin brazos

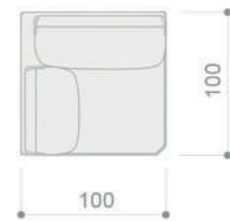

Rincón abierto

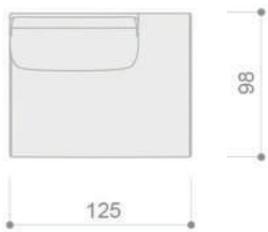

Terminal



Chaise Longue brazo corto

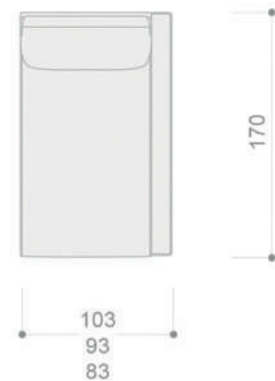

Chaise Longue brazo largo



Rincón terminal

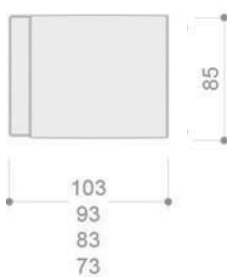

Posapiés con brazo

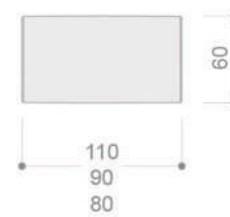

Posapiés

MISTRAL

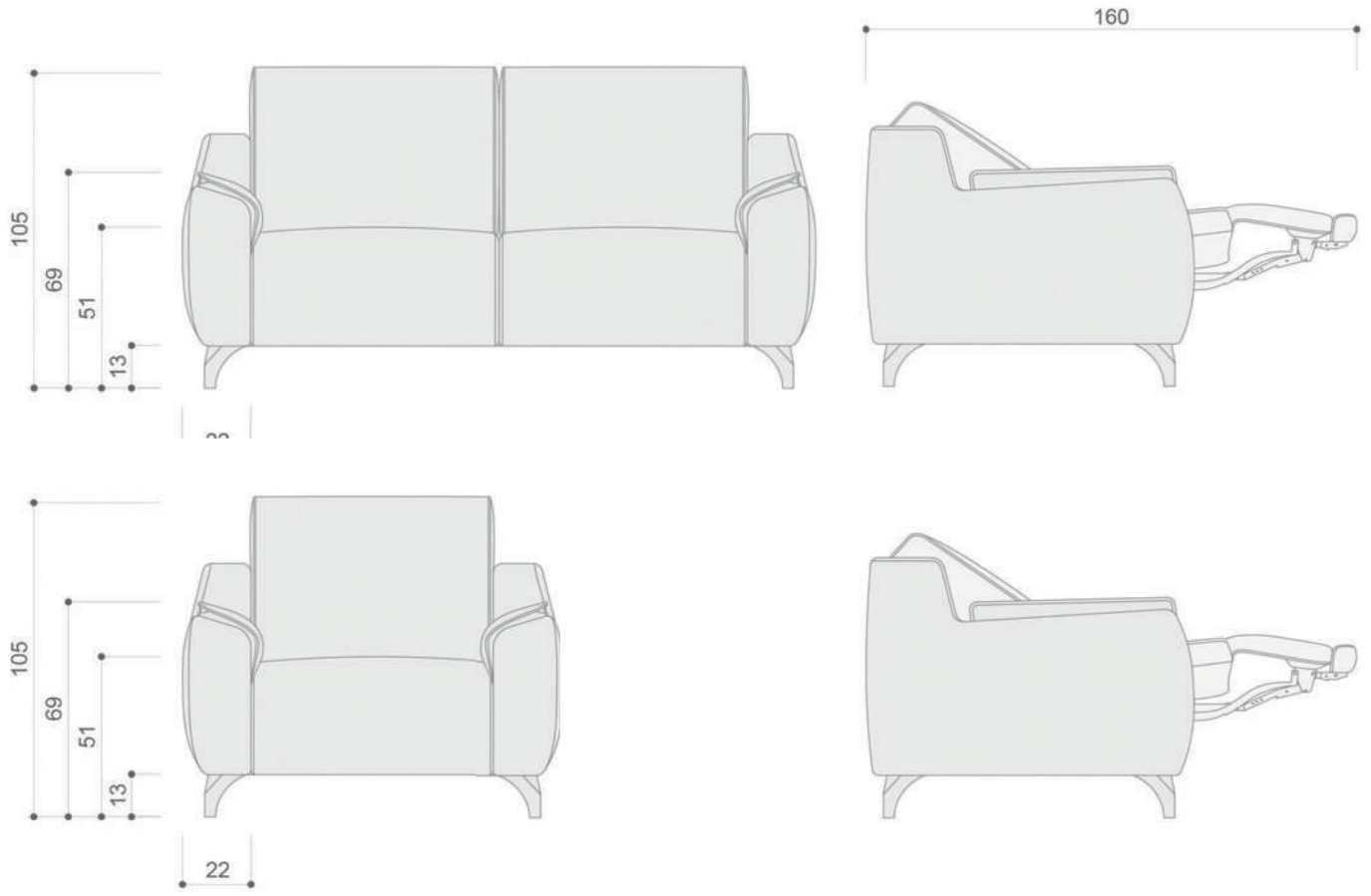

MISTRAL

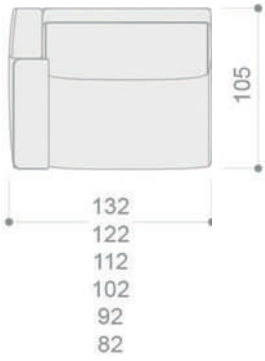

Módulo relax con 1 brazo

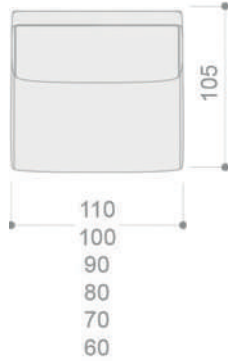

Módulo relax sin brazos

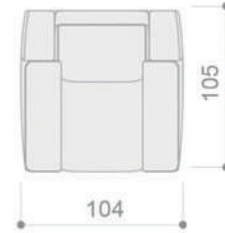

Butaca relax

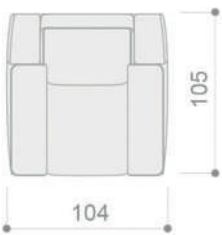

Butaca fija



Sofá fijo con 2 brazos

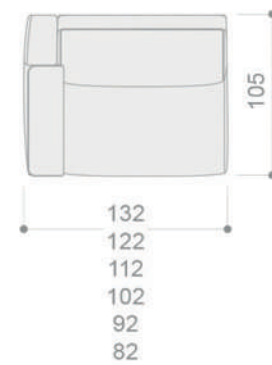

Módulo fijo con 1 brazo

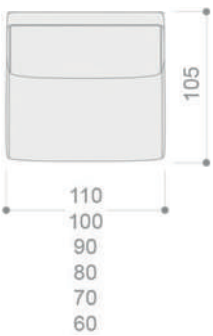

Módulo fijo sin brazos

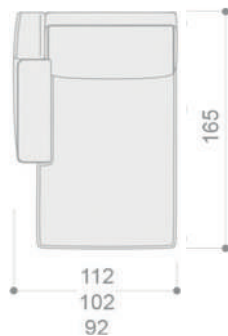

Chaise Longue

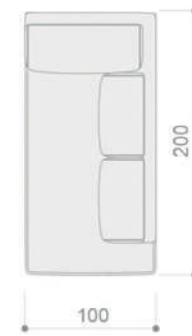

Rincón terminal

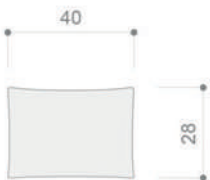

Almohadilla cabecera

NADIR

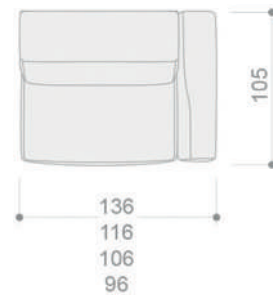
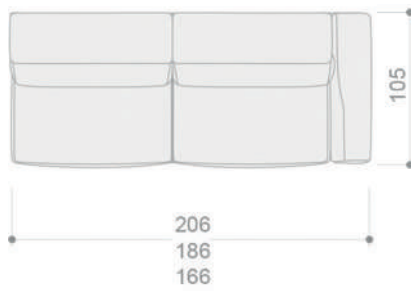
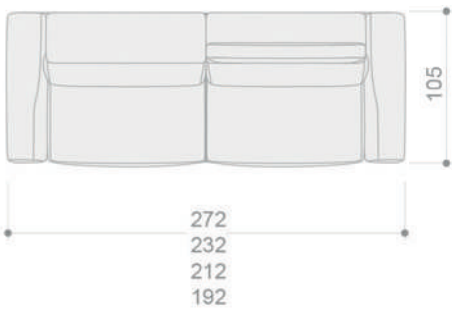

Sofá con 2 brazos

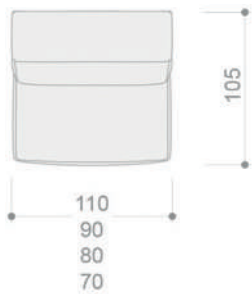

Sofá con 1 brazo



Módulo con 1 brazo

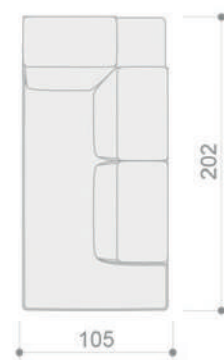

Módulo sin brazos

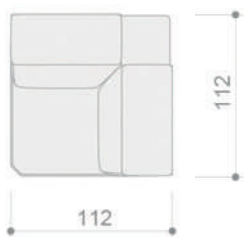

Chaise Longue con brazo corto

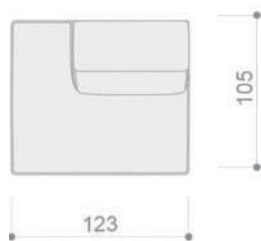

Rincón terminal

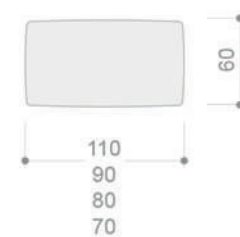

Rincón abierto

Terminal

Posapiés

OMEGA

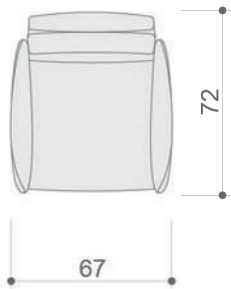
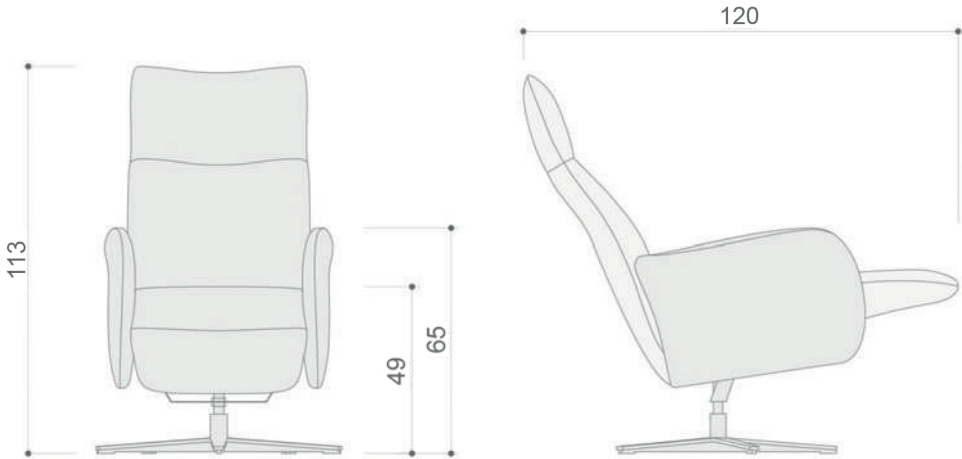

Butaca relax

PLATEA (PATA BAJA)

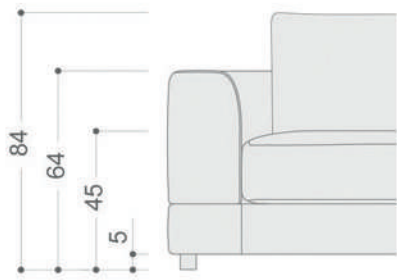

Respaldo bajo



Respaldo alto

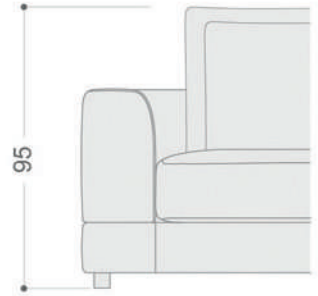

Respaldo doble

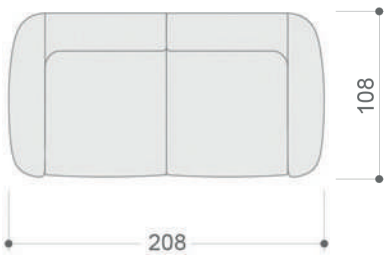

Sofá con 2 brazos

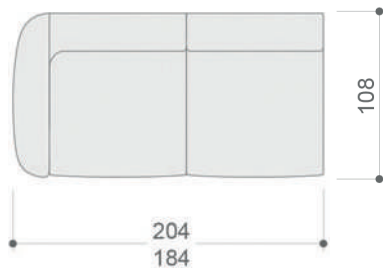

Sofá con 1 brazo

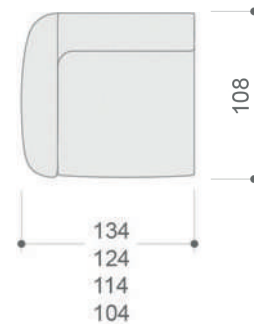

Módulo con 1 brazo

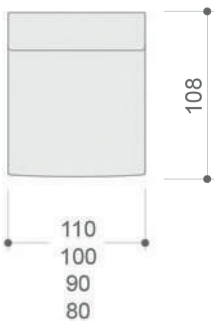

Módulo sin brazos

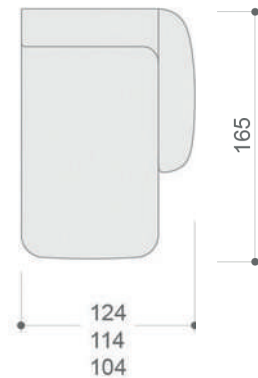

Chaise Longue

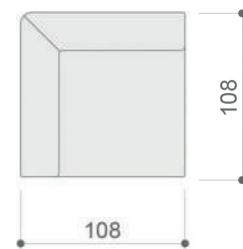

Rincón cerrado

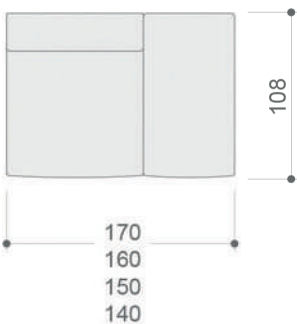

Módulo con posapiés

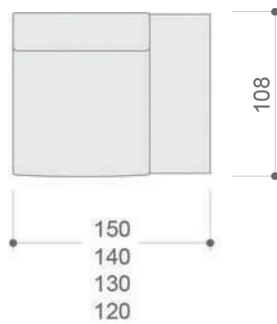

Módulo con mesa

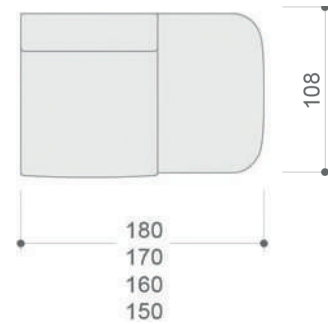

Módulo con mesa curva

PLATEA (PATA BAJA)

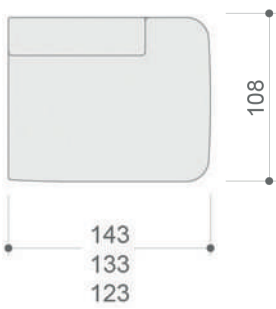

Terminal

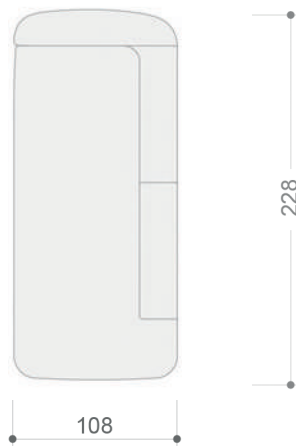

Sofá terminal

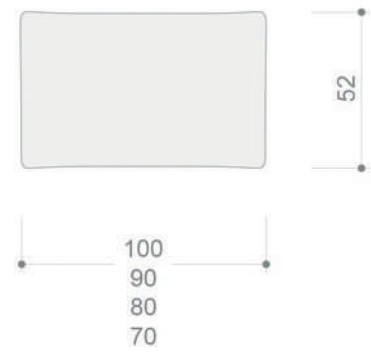

Respaldo pluma rulo

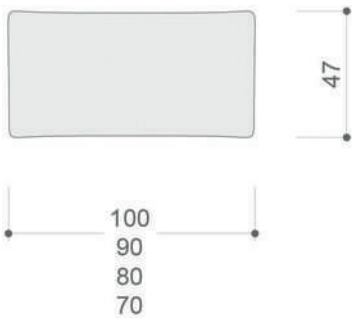

Respaldo pluma bajo

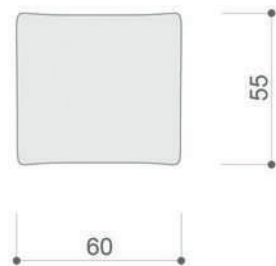

Respaldo fino microfibra

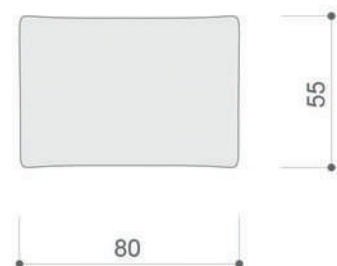

Respaldo fino microfibra

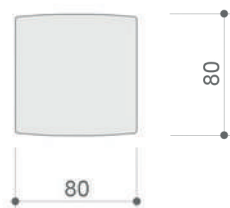

Posapiés cuadrado

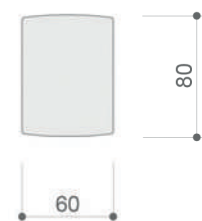

Posapiés rectangular

PLATEA (PATA ALTA)

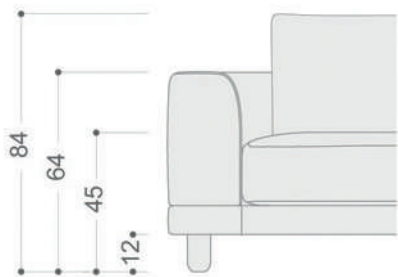

Respaldo bajo

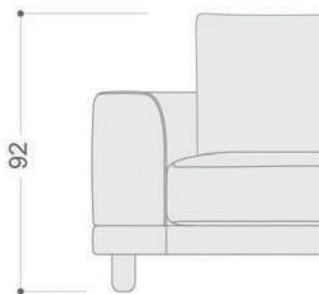

Respaldo alto

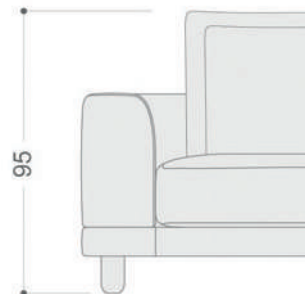

Respaldo doble

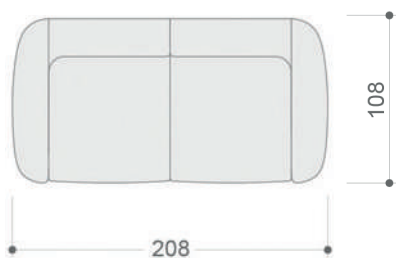

Sofá con 2 brazos



Sofá con 1 brazo

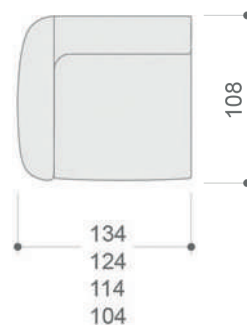

Módulo con 1 brazo

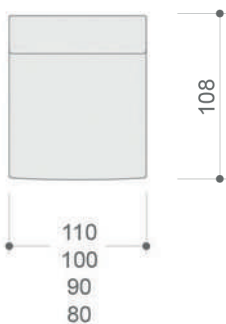

Módulo sin brazos

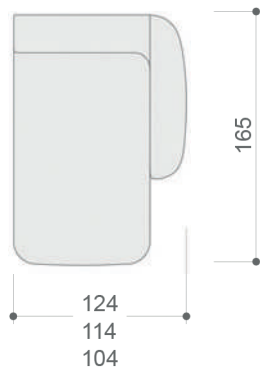

Chaise Longue

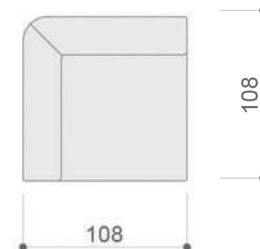

Rincón cerrado

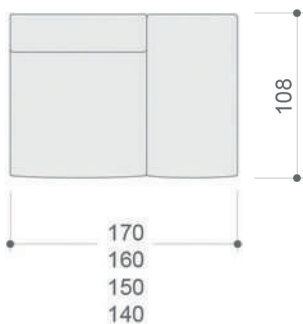

Módulo con posapiés

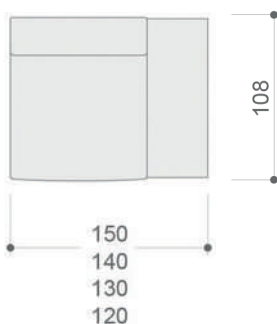

Módulo con mesa rectangular

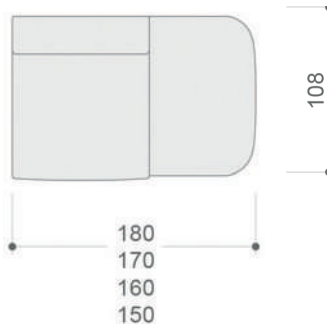

Módulo con mesa curva

PLATEA (PATA ALTA)

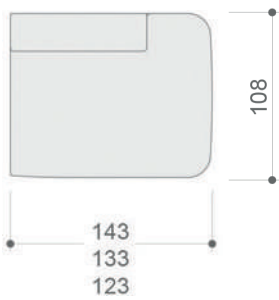

Terminal

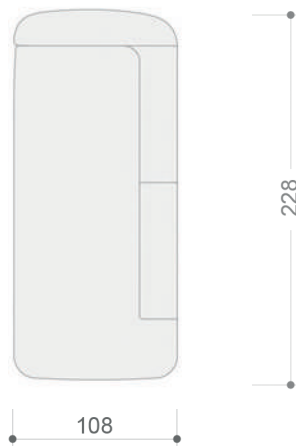

Sofá terminal

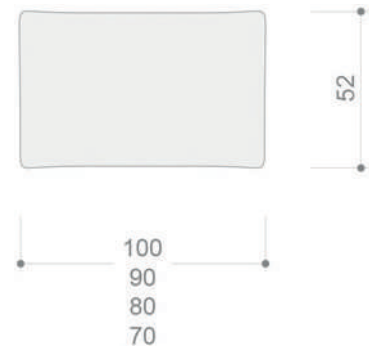

Respaldo pluma rulo

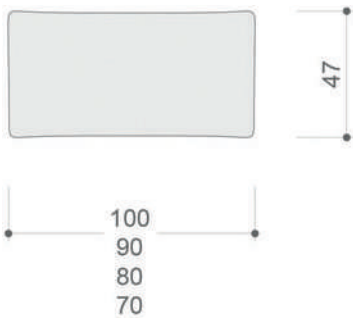

Respaldo pluma bajo

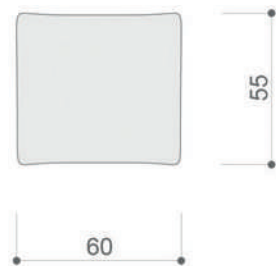

Respaldo fino microfibra

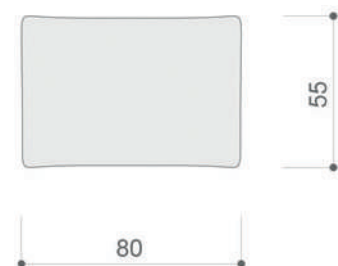

Respaldo fino microfibra

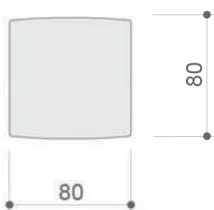

Posapiés cuadrado

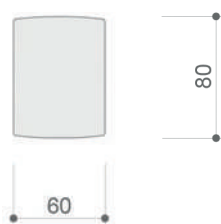

Posapiés rectangular

SIGMA

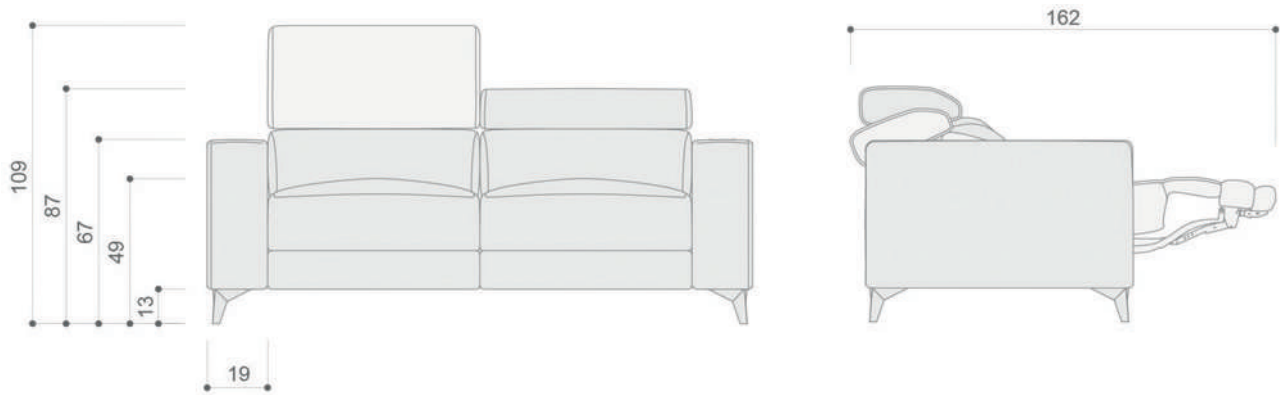

RESUMEN MEDIDAS SOFÁ SIGMA CON BRAZO SIGMA

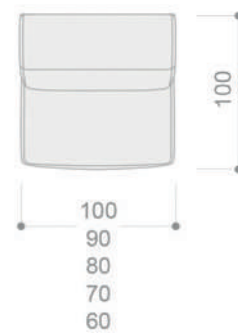
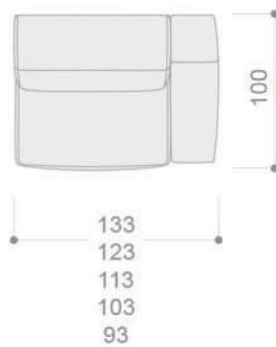
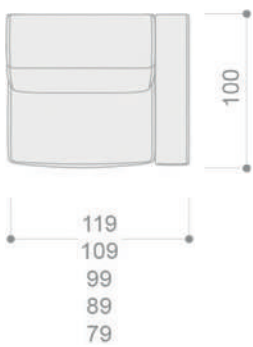

Módulo relax con 1 brazo sigma

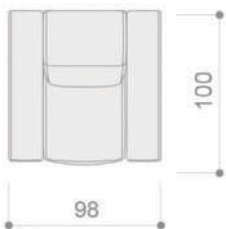

Módulo relax con 1 brazo kappa



Módulo relax sin brazos (compatible con brazo sigma y brazo kappa)



Butaca relax (con brazo Sigma)

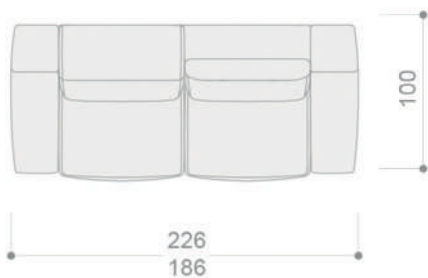

Butaca relax (con brazo Kappa)

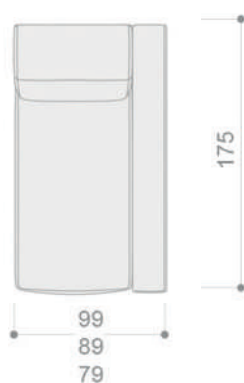

Sofá fijo (con 2 brazos Sigma)

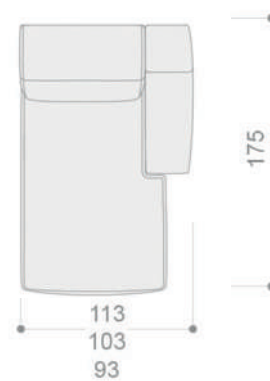

Sofá fijo (con 2 brazos Kappa)

Chaise Longue brazo largo sigma

Chaise Longue brazo corto kappa

SIGMA

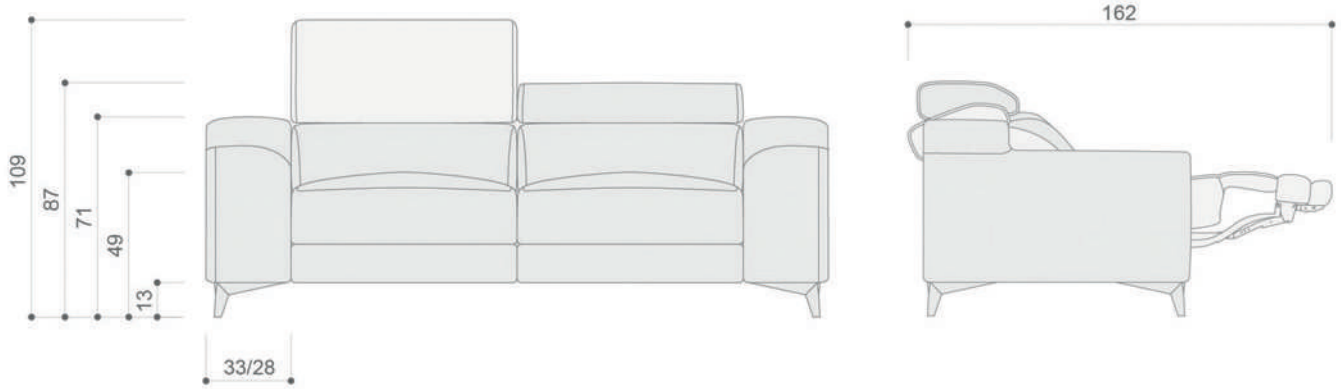

RESUMEN MEDIDAS SOFÁ SIGMA CON BRAZO KAPPA

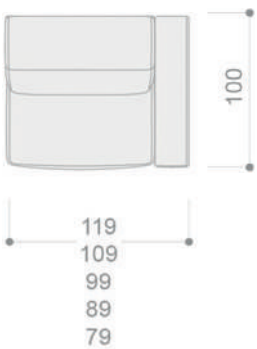

Módulo fijo con 1 brazo sigma

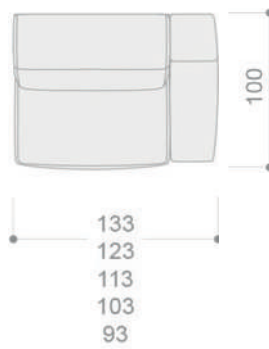

Módulo fijo con 1 brazo kappa

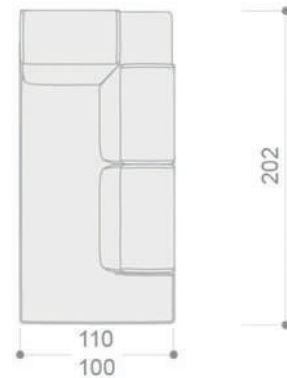

Rincón terminal (compatible con brazo sigma y brazo kappa)

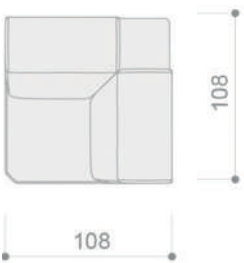

Rincón abierto (compatible con brazo sigma y brazo kappa)

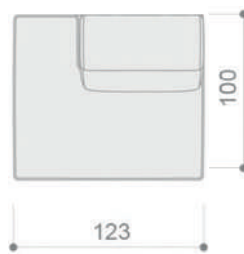

Terminal (compatible con brazo sigma y brazo kappa)

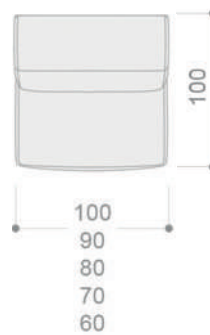

Módulo fijo sin brazos (compatible con brazo sigma y brazo kappa)

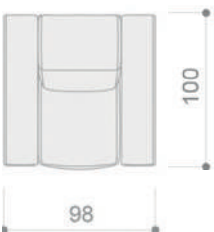

Butaca fija (con brazo Sigma)

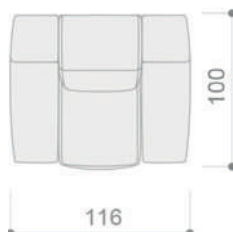

Butaca fija (con brazo Kappa)

SIROCCO ECO

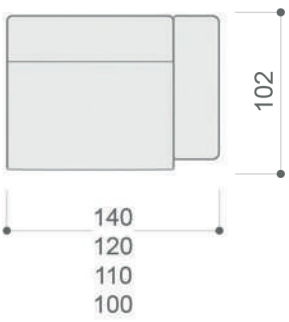
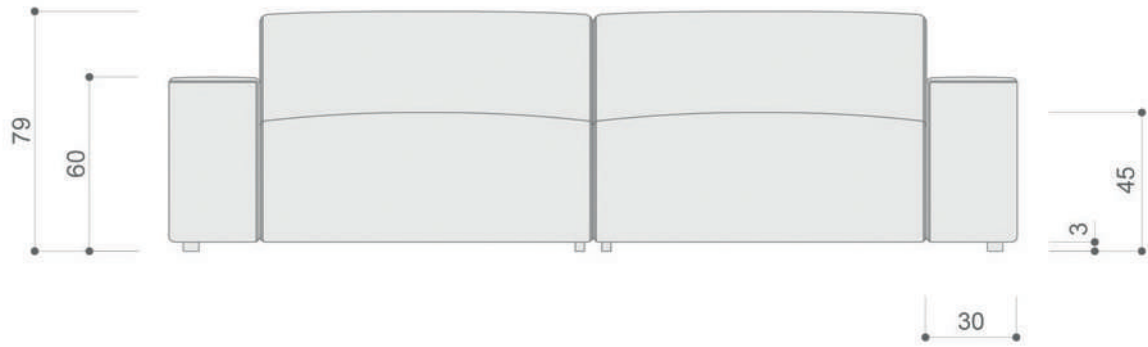

Módulo con 1 brazo

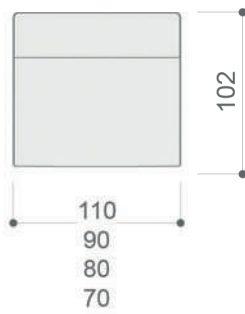

Módulo sin brazos

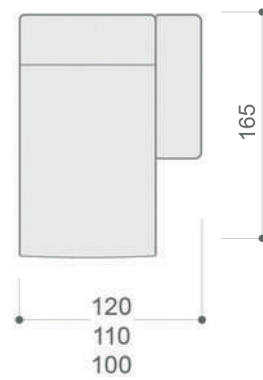

Chaise longue

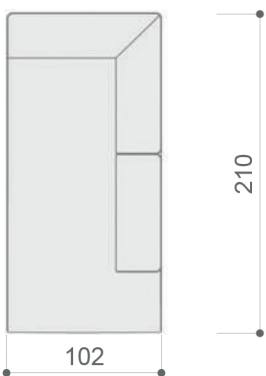

Rincón terminal

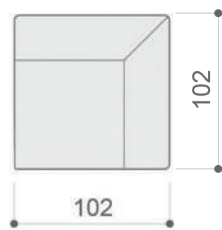

Rincón

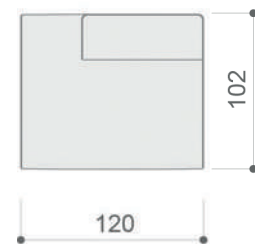

Terminal



TASSOS

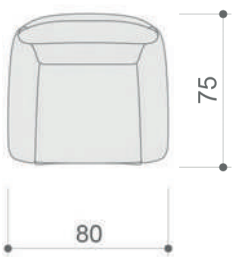
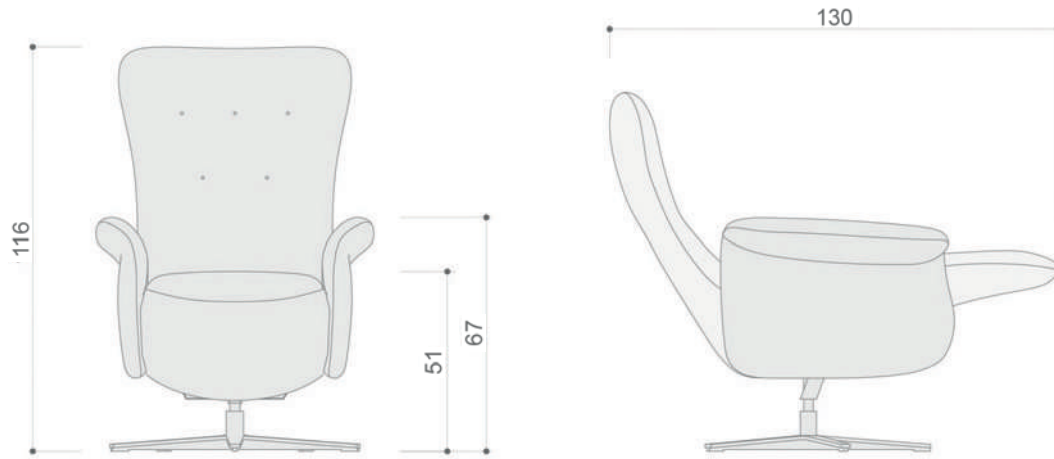

Butaca relax

TITA



Butaca

TUCSON

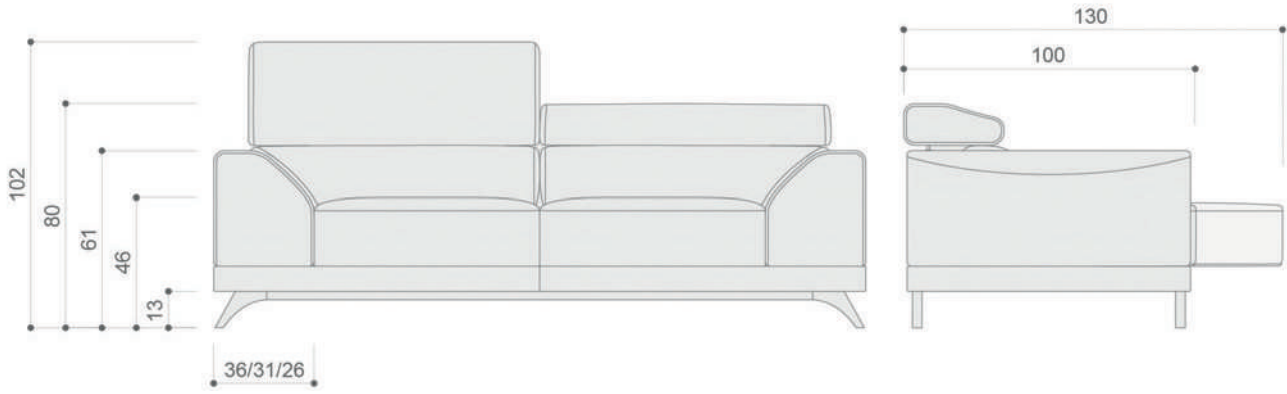

Sofá con 2 brazos

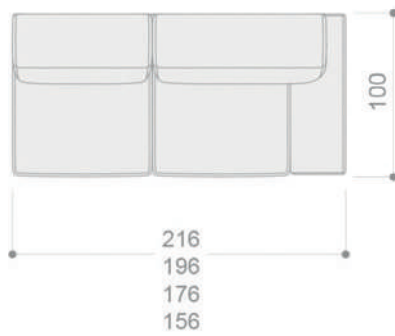

Sofá con 1 brazo

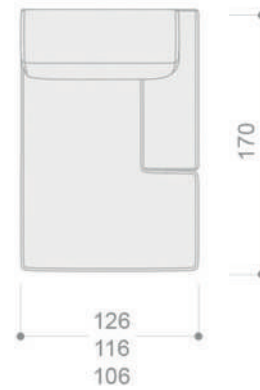

Chaise longue brazo corto

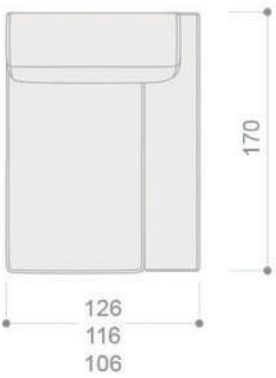

Chaise longue brazo largo

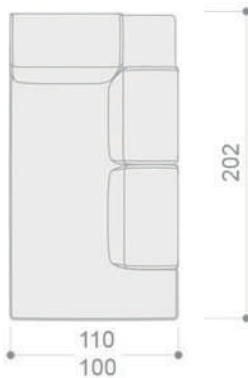

Rincón terminal

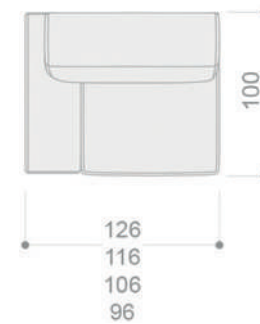

Módulo con 1 brazo

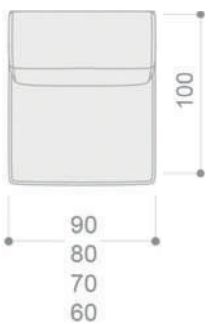

Módulo sin brazos

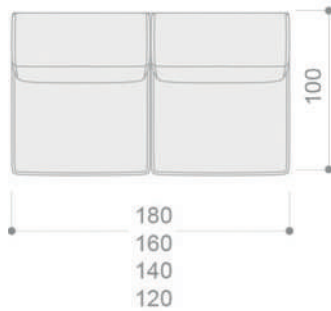

Sofá sin brazos

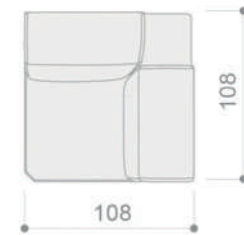

Rincón abierto

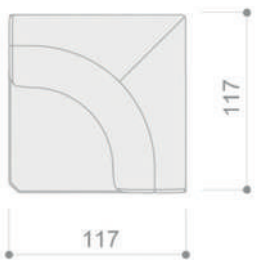

Rincón bajo



Posapiés rectangular

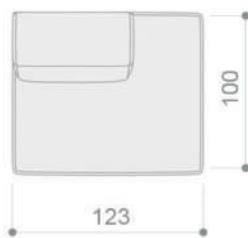

Terminal

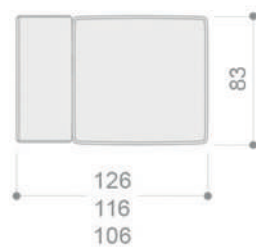

Posapiés con brazo

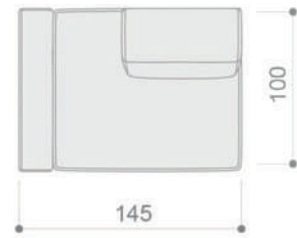

Terminal con repisa

TUNDRA

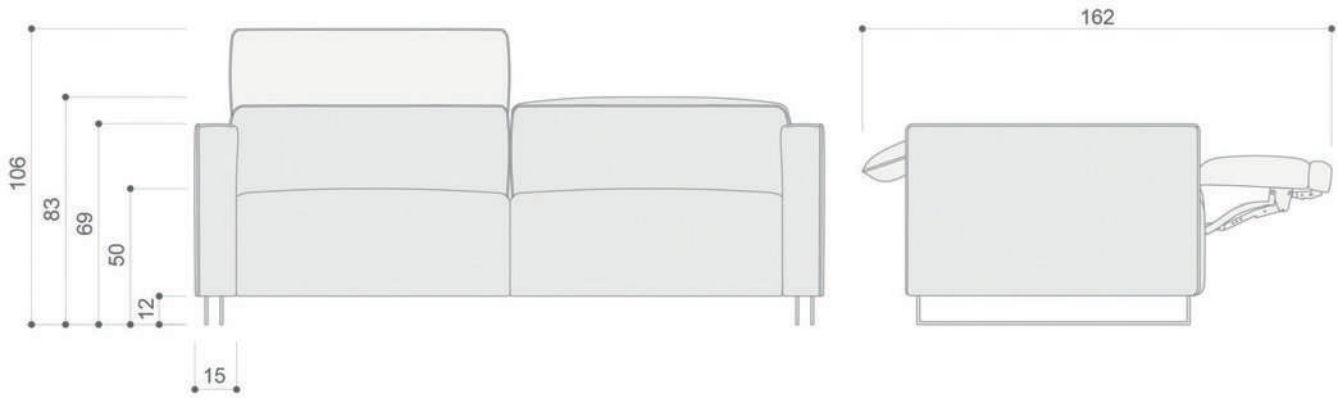

TUNDRA

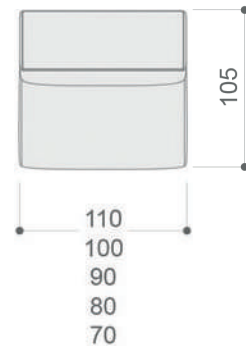
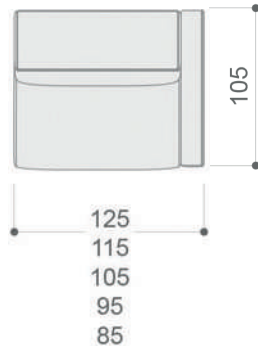
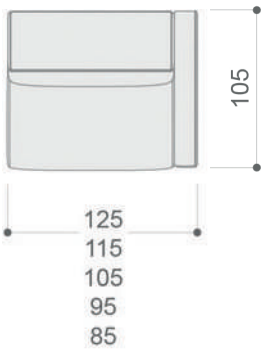

Módulo relax cabezal manual con 1 brazo

Módulo relax cabezal motor con 1 brazo

Módulo relax cabezal manual sin brazo

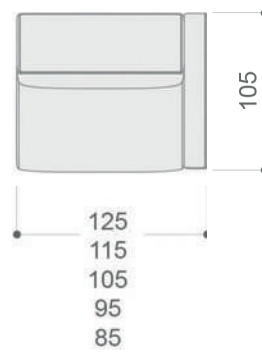
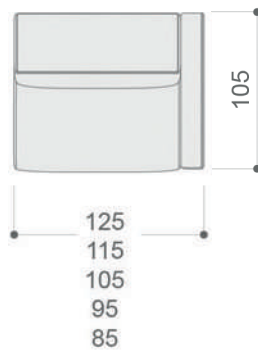
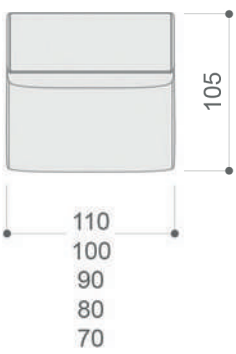

Módulo relax cabezal motor sin brazo

Módulo fijo cabezal manual con 1 brazo

Módulo fijo cabezal motor con 1 brazo

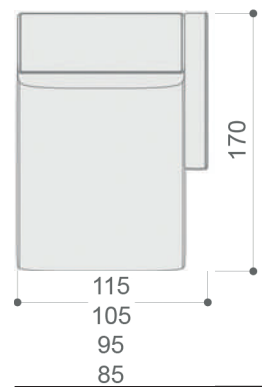
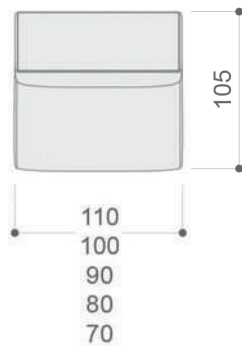
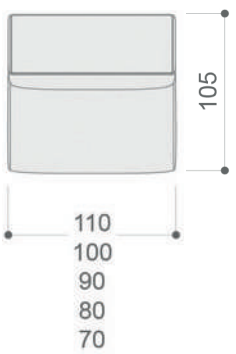

Módulo fijo cabezal manual sin brazo

Módulo fijo cabezal motor sin brazo

Chaise longue cabezal manual

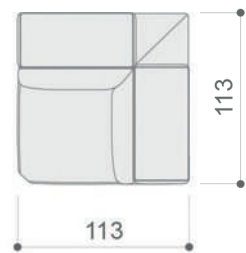
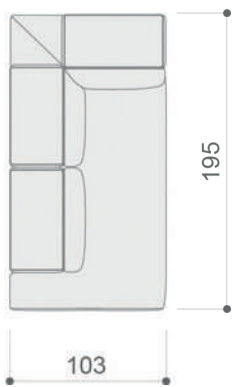
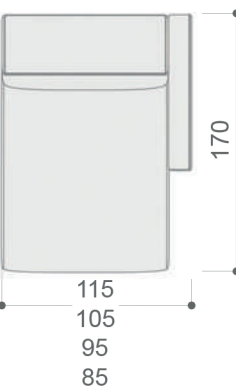

Chaise longue cabezal motor

Rincón terminal

Rincón abierto

YUTE

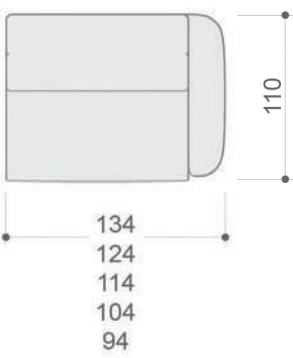
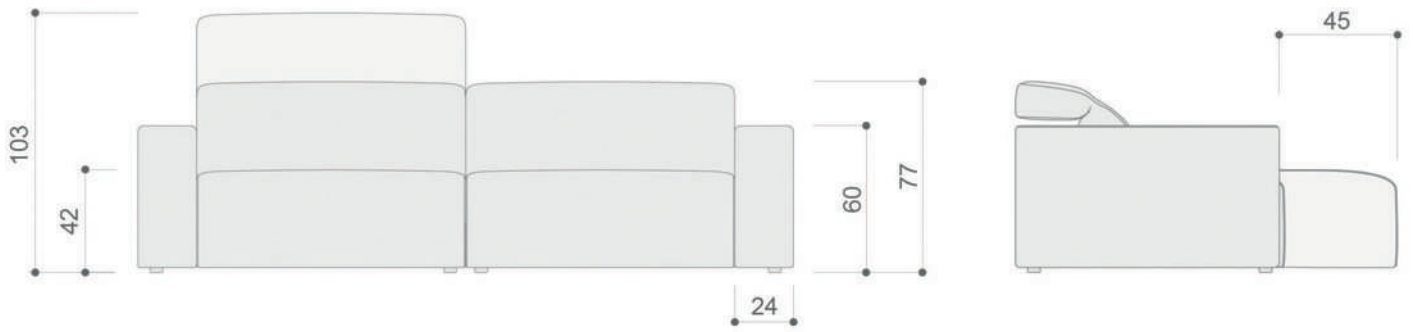

Módulo con 1 brazo

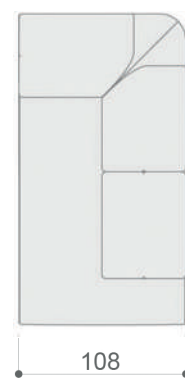
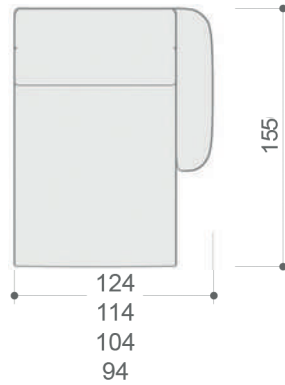
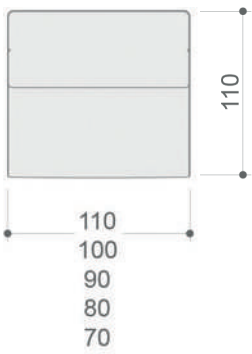

Módulo sin brazos

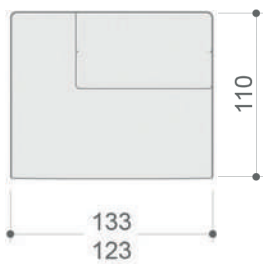

Chaise longue

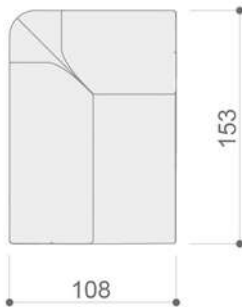

Rincón terminal

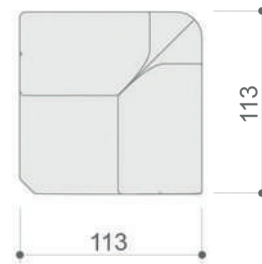

Terminal

Rincón rectangular

Rincón abierto

ZENITH

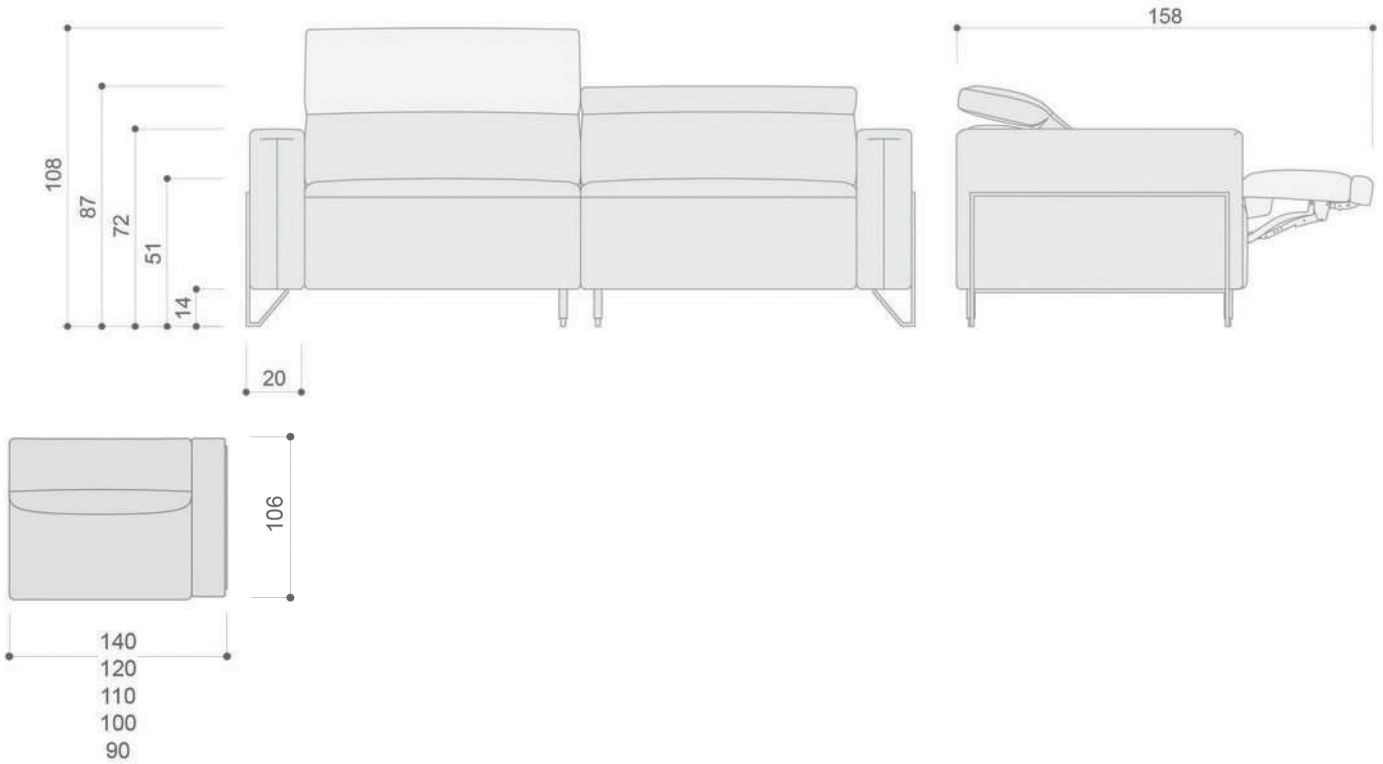

Módulo relax con 1 brazo

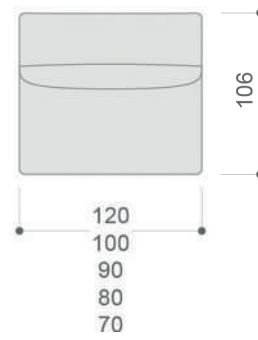
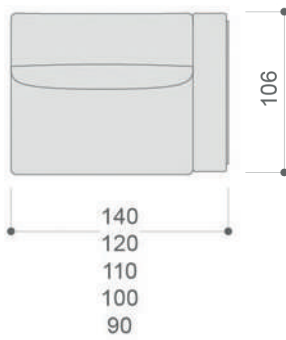
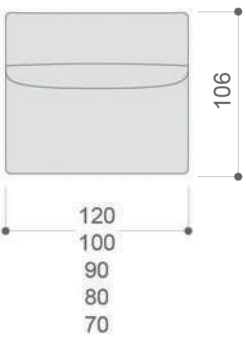

Módulo relax sin brazos

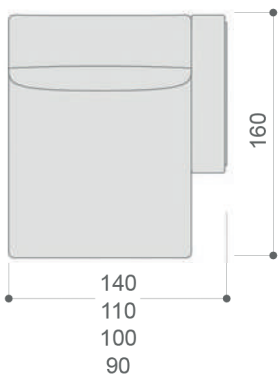

Módulo fijo con 1 brazo

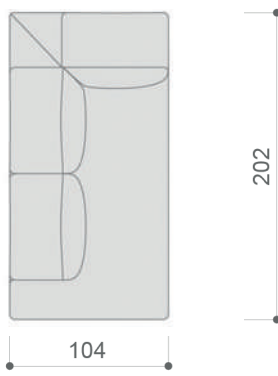

Módulo fijo sin brazos

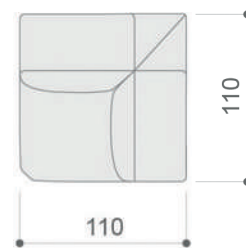

Chaise longue

Rincón terminal

Rincón abierto

ZONDA

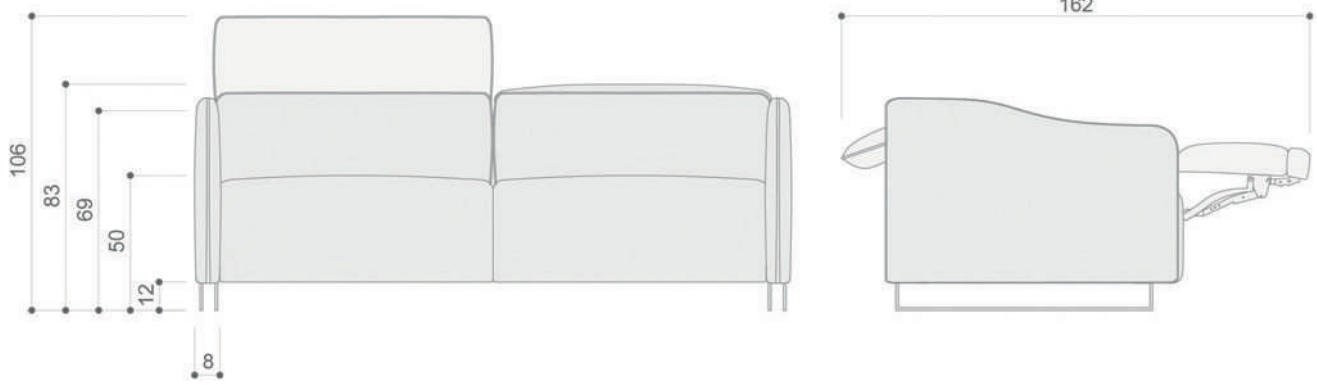

ZONDA

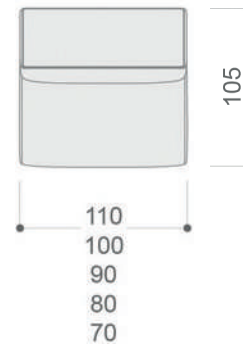
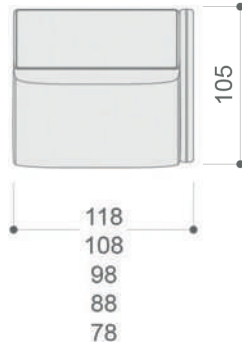
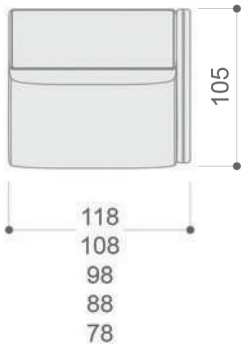

Módulo relax cabezal manual con 1 brazo

Módulo relax cabezal motor con 1 brazo

Módulo relax cabezal manual sin brazo

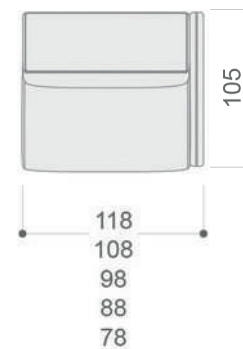
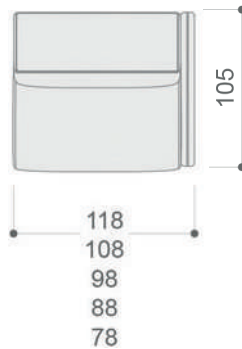
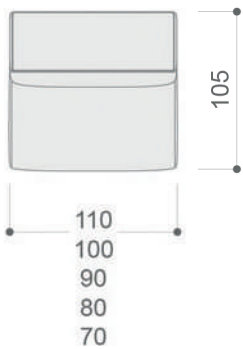

Módulo relax cabezal motor sin brazo

Módulo fijo cabezal manual 1 brazo

Módulo fijo cabezal motor con 1 brazo

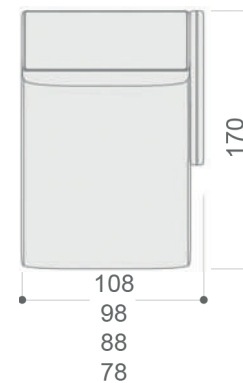
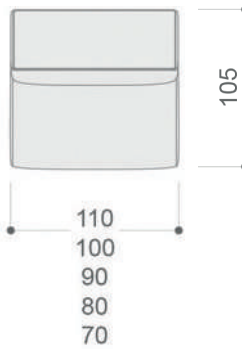
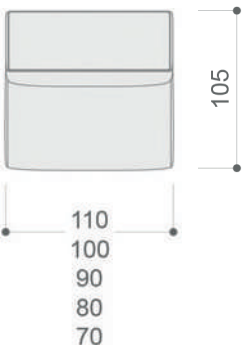

Módulo fijo cabezal manual sin brazo

Módulo fijo cabezal motor sin brazo

Chaise longue cabezal manual

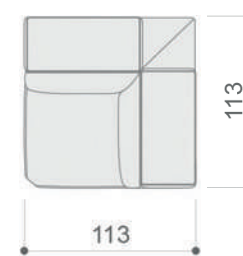
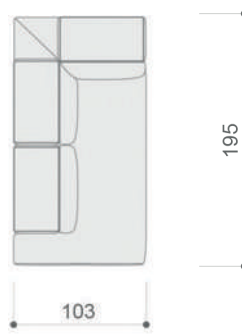
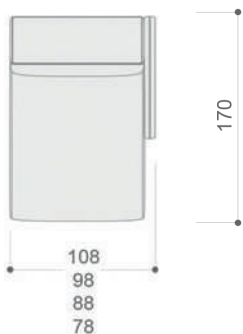

Chaise longue cabezal motor

Rincón terminal

Rincón abierto

REMO

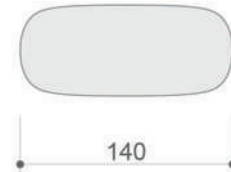
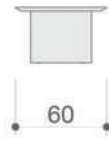

Mesa de centro 140x60 / h37cm

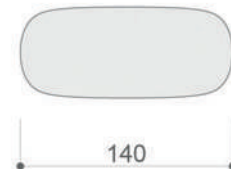
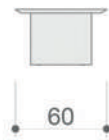

Mesa de centro 140x60 / h32cm

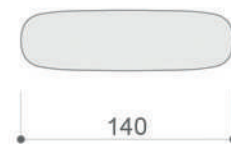

Mesa de centro 140x40 / h37cm

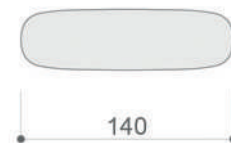

Mesa de centro 140x40 / h32cm

ISLA

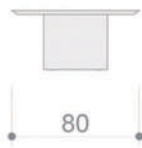

Mesa de centro 80cm / h37cm

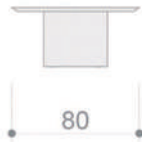

Mesa de centro 80cm / h32cm

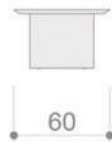

Mesa de centro 60cm / h37cm

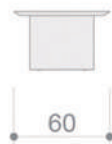

Mesa de centro 60cm / h32cm



Mesa de centro 120cm / h37cm



Mesa de centro 80cm / h37cm



Mesa de centro 60 / h37cm



Mesa de centro 120cm / h32cm



Mesa de centro 80cm / h32cm



Mesa de centro 60 / h32cm

POUFS

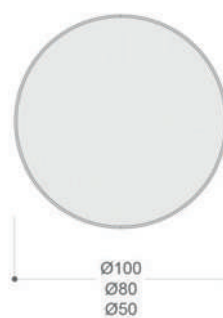

Pouf Redondo

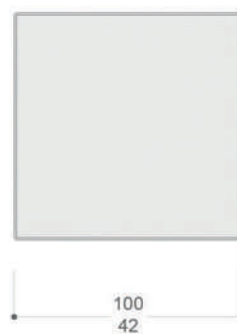

Pouf cuadrado



Taburete redondo

Créditos

Dirección:

Isabel Aguilar
Ismael Gallego

Jefe de producción:

Miguel Aguilar

Coordinador corte y costura:

Sergio Fuentes

Jefe de ventas:

Claudio Vila

Departamento técnico:

Michael Jensen

Internacional:

Vanessa Patteson

Control de calidad:

Ana Belén Aguilar

Atención al cliente:

Encarna Muñoz

Dirección artística:

Javier Guerrero

Fotografía:

Raúl Bartolomé
Javier Guerrero

Infografías:

Belén Iglesias

Ayte. Producción:

Eliana Lancheros

Maquetación:

Guerrero Estudio

Impresión:

Tanem S.L.

Damos las gracias a todos los distribuidores, colaboradores, clientes y proveedores que nos permiten mejorar día tras día, con especial atención a las siguientes empresas, entidades y amigos:

Agradecimientos empresas y entidades:

Hotel Six Senses Ibiza
Miguel Martí Gastronomía
BNI Empresarias
Interbuild
Harris Furnishings
LIA Proyectos
The Sofa Company
Pilma
Jover Sofás
Stua
Estudio Amaika
Loft Confort
Muebles Ulla
Kibuc Ulla
La vida es sueño
Portic Mobles
Procomobel
Castill Confort
Muebles Goterris
Mobles Pinell
Linea Confort
Mueblespaña
H.D. Mobiliario
Muebles Evelio
Pedro Concept
Beauty Home
Muebles Bernardo
Alado interioristas
Majo Flores interiorismo
Muebles Andrés Díaz

Agradecimientos a amigos:

Nacho Muelas
Alicia Pérez
M^a Carmen y Vicente Domingo
Carmelo Bueno
Jon Gasca
Jesús Giner
Daniel Díaz
Pepe Cosín
Rosalía Pons
Cristina Mares
Raúl Vega
Jose Luis Hervás

TEMASDOS

Polígono Industrial Albal
C/En Proyecto s/n
46470 Albal
Valencia
España

T: +34 961218120
info@temasdos.com
www.temasdos.com



TEMASDOS

www.temasdos.com